



Operating Instructions and Parts Manual
12" Sliding Dual Bevel Compound Miter Saw
Benchtop Series – Model No. JMS-12SCMS



WMH TOOL GROUP, Inc.
2420 Vantage Drive
Elgin, Illinois 60124
Ph.: 800-274-6848
www.wmhtoolgroup.com

Part No. M-707120
Revision A1 11/08
Copyright © 2008 WMH Tool Group, Inc.

Warranty and Service







WMH Tool Group, Inc., warrants every product it sells. If one of our tools needs service or repair, one of our Authorized Service Centers located throughout the United States can give you quick service. In most cases, any of these WMH Tool Group Authorized Service Centers can authorize warranty repair, assist you in obtaining parts, or perform routine maintenance and major repair on your JET® tools. For the name of an Authorized Service Center in your area call 1-800-274-6848.

MORE INFORMATION

WMH Tool Group is consistently adding new products to the line. For complete, up-to-date product information, check with your local WMH Tool Group distributor, or visit jettools.com.

WARRANTY

JET products carry a limited warranty which varies in duration based upon the product (MW stands for Metalworking, WW stands for Woodworking).

		Body Repair Kits Bottle Jacks Cable Pullers Cold Saws Hoists-Air Hoists-Electric Metal forming Mill/Drills Milling Machines MW Bandsaws MW Drill Presses MW Finishing Equipment MW Lathes MW Precision Vises		Palet Trucks Rigging Equip. Service Jacks Stackers Surface Grinders Tapping Trolleys-Air Trolleys-Electric Web Slings Winches-Electric		WW Benchtop Tools		Beam Clamps Chain Hoist-Manual Lever Hoists Pullers-JCH Models Scissor Lift Tables Screw Jacks Trolleys-Gearred Trolleys-Plain Winches-Manual WW Air Filtration WW Bandsaws WW Buffers	WW Drill Presses WW Dust Collectors WW Dust Filters WW Dust Fittings WW Jointers WW Lathes WW Planers WW Sanders WW Shapers WW Tablesaws		Fastening Tools Mechanics Hand Tools Striking Tools Vises (no -precision) Clamps
Warranty reverts to 1 Year Warranty if woodworking (WW) products listed above are used for industrial or educational purposes.											

WHAT IS COVERED?

This warranty covers any defects in workmanship or materials subject to the exceptions stated below. Cutting tools, abrasives and other consumables are excluded from warranty coverage.

WHO IS COVERED?

This warranty covers only the initial purchaser of the product.

WHAT IS THE PERIOD OF COVERAGE?

The general JET warranty lasts for the time period specified in the product literature of each product.

WHAT IS NOT COVERED?

Three Year, Five Year and Lifetime Warranties do not cover products used for industrial or educational purposes. Products with Three Year, Five Year or Lifetime Warranties that are used for industrial or education purposes revert to a One Year Warranty. This warranty does not cover defects due directly or indirectly to misuse, abuse, negligence or accidents, normal wear-and-tear, improper repair or alterations, or lack of maintenance.

HOW TO GET SERVICE

The product or part must be returned for examination, postage prepaid, to a location designated by us. For the name of the location nearest you, please call 1-800-274-6848.

You must provide proof of initial purchase date and an explanation of the complaint must accompany the merchandise. If our inspection discloses a defect, we will repair or replace the product, or refund the purchase price, at our option. We will return the repaired product or replacement at our expense unless it is determined by us that there is no defect, or that the defect resulted from causes not within the scope of our warranty in which case we will, at your direction, dispose of or return the product. In the event you choose to have the product returned, you will be responsible for the shipping and handling costs of the return.

HOW STATE LAW APPLIES

This warranty gives you specific legal rights; you may also have other rights which vary from state to state.

LIMITATIONS ON THIS WARRANTY

WMH TOOL GROUP LIMITS ALL IMPLIED WARRANTIES TO THE PERIOD OF THE LIMITED WARRANTY FOR EACH PRODUCT. EXCEPT AS STATED HEREIN, ANY IMPLIED WARRANTIES OR MERCHANTABILITY AND FITNESS ARE EXCLUDED. SOME STATES DO NOT ALLOW LIMITATIONS ON HOW LONG THE IMPLIED WARRANTY LASTS, SO THE ABOVE LIMITATION MAY NOT APPLY TO YOU.

WMH TOOL GROUP SHALL IN NO EVENT BE LIABLE FOR DEATH, INJURIES TO PERSONS OR PROPERTY, OR FOR INCIDENTAL, CONTINGENT, SPECIAL, OR CONSEQUENTIAL DAMAGES ARISING FROM THE USE OF OUR PRODUCTS. SOME STATES DO NOT ALLOW THE EXCLUSION OR LIMITATION OF INCIDENTAL OR CONSEQUENTIAL DAMAGES, SO THE ABOVE LIMITATION OR EXCLUSION MAY NOT APPLY TO YOU.

WMH Tool Group sells through distributors only. The specifications in WMH catalogs are given as general information and are not binding. Members of WMH Tool Group reserve the right to effect at any time, without prior notice, those alterations to parts, fittings, and accessory equipment which they may deem necessary for any reason whatsoever. JET® branded products are not sold in Canada by WMH Tool Group.

Table of Contents

Warranty and Service	2
Table of Contents	3
Warnings.....	5
Compound Miter Saw Safety	7
Introduction	8
Specifications.....	8
Cutting Capacity	8
Electrical	9
Power Supply and Motor Specifications	9
Electrical Requirements	9
Extension Cords.....	9
Features.....	10
Shipping Contents	11
Contents of the Shipping Container	11
Assembly	12
Unlocking the Slide Carriage	12
Releasing the Cutting Head	12
Unlocking.....	12
Locking	12
Installing the Dust Bag	12
Installing the Safety Hold-down Clamp.....	13
Power Cord Storage Clips	13
Saw Blade Wrench	13
Table Inserts	14
Mounting the Saw	14
Removing the Blade.....	14
Installing Blade.....	15
Adjustments	16
Bevel Stop Adjustments.....	16
90°(0°) Bevel Adjustment	16
Bevel Scale Indicators.....	16
45° Left Bevel Positive Stop Adjustment.....	16
45° Right Bevel Positive Stop Adjustment	17
33.9° Left & Right Bevel Adjustment	17
Miter Angle	18
Miter Scale Indicator Adjustment.....	18
Adjusting Fence Squareness	18
Positive Stop Miter Angle Adjustment.....	19
Quick-cam Miter Table Lock Operation	19
Quick-cam Miter Table Lock Adjustment.....	19
Presetting the Cutting Depth.....	20
Rear Support Bar	20
Laser Beam.....	20
Operation	21
Starting a cut.....	21
Finishing a cut.....	21
Jammed Material.....	21
To Turn the Saw On.....	21
Sliding Fence	22
Removing or Installing the Sliding Fence	22
Sliding Carriage System	22
Miter Cut.....	23
Bevel Cut.....	23
33.9° Bevel Detent Pin for Crown Moldings.....	24
Compound Cuts	24
90° Crosscut – Narrow Boards	24
Slide Cutting Wide Boards	25

Cutting Bowed Material.....	26
Rough Cutting a Dado	26
Auxiliary Wood Fence	26
Changing the Belt.....	26
Cutting Base Molding.....	27
Bevel/Miter Settings.....	27
Crown Molding.....	27
Crown Molding Chart.....	28
Maintenance	29
Replacing Carbon Brushes	29
Lower Blade Guard	29
Saw Dust.....	29
Lubrication.....	29
Troubleshooting – Motor.....	30
Troubleshooting – Operation	30
Parts	31
Ordering Replacement Parts	31
Parts List	31
Assembly Drawing	36
Wiring Diagram.....	39

The specifications in this manual are given as general information and are not binding. WMH Tool Group, Inc. reserves the right to effect, at any time and without prior notice, changes or alterations to parts, fittings, and accessory equipment deemed necessary for any reason whatsoever.



Warnings

1. Read and understand the entire owners' manual before attempting assembly or operation.
2. Read and understand the warnings posted on the machine and in this manual. Failure to comply with all of these warnings may cause serious injury.
3. Replace the warning labels if they become obscured or removed.
4. This saw is designed and intended for use by properly trained and experienced personnel only. If you are not familiar with the proper and safe operation of a compound miter saw, do not use until proper training and knowledge have been obtained.
5. Do not use this saw for other than its intended use. If used for other purposes, WMH Tool Group disclaims any real or implied warranty and holds itself harmless from any injury that may result from that use.
6. Always wear approved safety glasses/face shields while using this miter saw. Everyday eyeglasses only have impact resistant lenses; they are not safety glasses.
7. Before operating this saw, remove tie, rings, watches and other jewelry, and roll sleeves up past the elbows. Remove all loose clothing and confine long hair. Non-slip footwear or anti-skid floor strips are recommended. Do **not** wear gloves.
8. Wear ear protectors (plugs or muffs) during extended periods of operation.
9. Some dust created by power sanding, sawing, grinding, drilling and other construction activities contain chemicals known to cause cancer, birth defects or other reproductive harm. Some examples of these chemicals are:
 - Lead from lead based paint.
 - Crystalline silica from bricks, cement and other masonry products.
 - Arsenic and chromium from chemically treated lumber.Your risk of exposure varies, depending on how often you do this type of work. To reduce your exposure to these chemicals, work in a well-ventilated area and work with approved safety equipment, such as face or dust masks that are specifically designed to filter out microscopic particles.
10. Do not operate this machine while tired or under the influence of drugs, alcohol or any medication.
11. Make certain the switch is in the **OFF** position before connecting the machine to the power supply.
12. Make certain the machine is properly grounded.
13. Make all machine adjustments or maintenance with the machine unplugged from the power source.
14. Remove adjusting keys and wrenches. Form a habit of checking to see that keys and adjusting wrenches are removed from the machine before turning it on.
15. Keep safety guards in place at all times when the machine is in use. If removed for maintenance purposes, use extreme caution and replace the guards immediately.
16. Make sure this machine is firmly secured to the floor or bench before use.
17. Check damaged parts. Before further use of the machine, a guard or other part that is damaged should be carefully checked to determine that it will operate properly and perform its intended function. Check for alignment of moving parts, binding of moving parts, breakage of parts, mounting and any other conditions that may affect its operation. A guard or other part that is damaged should be properly repaired or replaced.
18. Provide for adequate space surrounding work area and non-glare, overhead lighting.
19. Keep the floor around the machine clean and free of scrap material, oil and grease.
20. Don't use in dangerous environment. Don't use power tools in damp or wet locations, or expose them to rain. Keep work area well lighted.
21. Keep visitors a safe distance from the work area. **Keep children away.**
22. Make your workshop child proof with padlocks, master switches or by removing starter keys.

Warnings

23. Give your work undivided attention. Looking around, carrying on a conversation and “horse-play” are careless acts that can result in serious injury.
24. Maintain a balanced stance at all times so that you do not fall or lean against the blade or other moving parts. Do not overreach or use excessive force to perform any machine operation.
25. Use the right tool at the correct speed and feed rate. Do not force a tool or attachment to do a job for which it was not designed. The right tool will do the job better and safer.
26. Use recommended accessories; improper accessories may be hazardous.
27. Maintain tools with care. Keep saw blades sharp and clean for the best and safest performance. Follow instructions for lubricating and changing accessories.
28. Disconnect tools before servicing and when changing accessories such as blades.
29. Make sure the work piece is securely attached or clamped to the table.
30. Turn off the machine before cleaning. Use a brush or compressed air to remove chips or debris — do not use your hands.
31. Do not stand on the machine. Serious injury could occur if the machine tips over.
32. Never leave the machine running unattended. Turn the power off and do not leave the machine until it comes to a complete stop.
33. Remove loose items and unnecessary work pieces from the area before starting the machine.

Familiarize yourself with the following safety notices used in this manual:



This means that if precautions are not heeded, it may result in minor injury and/or possible machine damage.



This means that if precautions are not heeded, it may result in serious injury or possibly even death.

Compound Miter Saw Safety

Specific safety instructions for this compound miter saw

1. Do not operate the miter saw until it is completely assembled and installed according to these instructions.
2. If you are not thoroughly familiar with the operation of miter saws, seek guidance from your supervisor, instructor or other qualified person.
3. Always hold the work firmly against the fence and table.
4. Do not perform any operation free hand (use clamp wherever possible).
5. Keep hands out of the path of the saw blade. If the workpiece you are cutting would cause your hands to be within 8-3/4 in. of the saw blade, the workpiece should be clamped in place before making the cut.
6. Be sure the blade is sharp, runs freely and is free of vibration.
7. Allow the motor to come up to full speed before starting a cut.
8. Keep the motor air slots clean and free of chips or dust.
9. Always make sure all handles are tight before cutting, even if the table is positioned in one of the positive stops.
10. Be sure both the blade and the collar are clean and the arbor bolt is tightened securely.
11. Use only blade collars specified for your saw.
12. Never use blades larger in diameter than 12 inches.
13. Never apply lubricants to the blade when it is running.
14. Always check the blade for cracks or damage before operation. Replace a cracked or damaged blade immediately.
15. Never use blades recommended for operation at less than 4200 RPM.
16. Always keep the blade guards in place and use at all times.
17. Never reach around the saw blade.
18. Make sure the blade is not contacting the workpiece before the switch is turned ON.
19. Important: After completing the cut, release the trigger and wait for the blade to stop before returning the saw to the raised position.
20. Make sure the blade has come to a complete stop before removing or securing the workpiece, changing the workpiece angle or changing the angle of the blade.
21. Never cut metals or masonry products with this tool. This miter saw is designed for use on wood and wood-like products.
22. Never cut small pieces. If the workpiece being cut would cause your hand or fingers to be within 8-3/4 in. of the saw blade the workpiece is too small.
23. Provide adequate support to the sides of the saw table for long work pieces.
24. Never use the miter saw in an area with flammable liquids or gases.
25. Never use solvents to clean plastic parts. Solvents could possibly dissolve or otherwise damage the material.
26. Shut off the power before servicing or adjusting the tool.
27. Disconnect the saw from the power source and clean the machine when finished using.
28. Make sure the work area is clean before leaving the machine.
29. Should any part of your miter saw be missing, damaged, or fail in any way, or any electrical component fail to perform properly, lock the switch and remove the plug from the power supply outlet. Replace missing, damaged, or failed parts before resuming operation.

Introduction

This manual is provided by WMH Tool Group covering the safe operation and maintenance procedures for the JET Model JMS-12SCMS *Dual Bevel Sliding Compound Miter Saw* with laser. This manual contains instructions on installation, safety precautions, general operating procedures, maintenance instructions and parts breakdown. This machine has been designed and constructed to provide years of trouble free operation if used in accordance with instructions set forth in this manual. If there are any questions or comments, please contact either your local supplier or WMH Tool Group. WMH Tool Group can also be reached at our web site: www.wmhtoolgroup.com.

Specifications

Model Number..... JMS-12SCMS
 Stock Number 707120
 Motor 120V, 60Hz, 15A
 No Load Speed (Arbor)..... 4200RPM
 Motor Arbor Shaft Size..... 5/8"
 Blade 12", 60T, carbide tipped
 Blade Arbor Size 1" with 5/8" reducer
 Net Weight..... 72 lb.

The above specifications were current at the time this manual was published, but because of our policy of continuous improvement, WHM Tool Group reserves the right to change specifications at any time and without prior notice, without incurring obligations.

Cutting Capacity

Cut Type	Miter Angle	Bevel Angle	Cutting Capacity
Cross Cut	0°	0°	4" x 12-1/4"
Miter	45° Right & Left	0°	4" x 8-3/4"
Miter	60° Right	0°	4" x 6-1/4"
Bevel	0°	45° Left	2-1/2" x 12-1/4"
Bevel	0°	45° Right	1-3/4" x 12-1/4"
Compound Cut	45° Right & Left	45° Left	2-1/2" x 8-3/4"
Compound Cut	45° Right & Left	45° Right	1-3/4" x 8-3/4"
Compound Cut	60° Right	45° Right	1-3/4" x 6-1/4"
Vertical Capacity (Baseboard)	0°	0°	5-1/2"

⚠WARNING Read and understand the entire contents of this manual before attempting assembly or operation! Failure to comply may cause serious injury!

Electrical

Power Supply and Motor Specifications

The AC motor used in this saw is a universal, nonreversible type (see *Motor* in the *Specifications* section on page 7).

⚠ WARNING To avoid electrical hazards, fire hazards, or damage to the machine, use proper circuit protection. Your saw is wired at the factory for 120V operation. Connect to a 120V, 15 Amp circuit and use a 15 amp time delay fuse or circuit breaker. If power cord is worn or cut, or damaged in any way, have it replaced immediately to avoid shock or fire.

Electrical Requirements

This machine is double insulated to provide a double thickness of insulation between the user and the machine's electrical system. All exposed metal parts are isolated from the internal metal motor components with protective insulation.

This saw has a plug that looks like the one shown in Figure A.

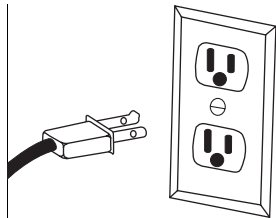

Figure A

To reduce the risk of electrical shock, this saw has a polarized plug (one blade is wider than the other). This plug will fit in a polarized outlet only one way; if the plug does not fit fully in the outlet, reverse the plug. If it still does not fit, contact a qualified electrician to install the proper outlet. Do not change the plug in any way.

Double insulation does not take the place of normal safety precautions when operating this tool.

To avoid electrocution:

1. Use only identical replacement parts when servicing a tool with double insulation. Servicing should be performed by a qualified technician.
2. Do not use power tools in wet or damp locations or expose them to rain or snow.

Extension Cords

Make sure your extension cord is in good condition. When using an extension cord, be sure to use one heavy enough to carry the current your machine will draw. An undersized cord will cause a drop in the line voltage resulting in power loss and overheating. The table below shows the correct size to use depending on the cord length and nameplate ampere rating. If in doubt, use the next heavier gauge. Remember, the smaller the gauge number, the heavier the cord.

Cord Length	AWG
0 – 25ft	16
5 – 50ft	14

Important: Make certain the receptacle in question is properly grounded. If you are not sure, have a registered electrician check the receptacle.

Features

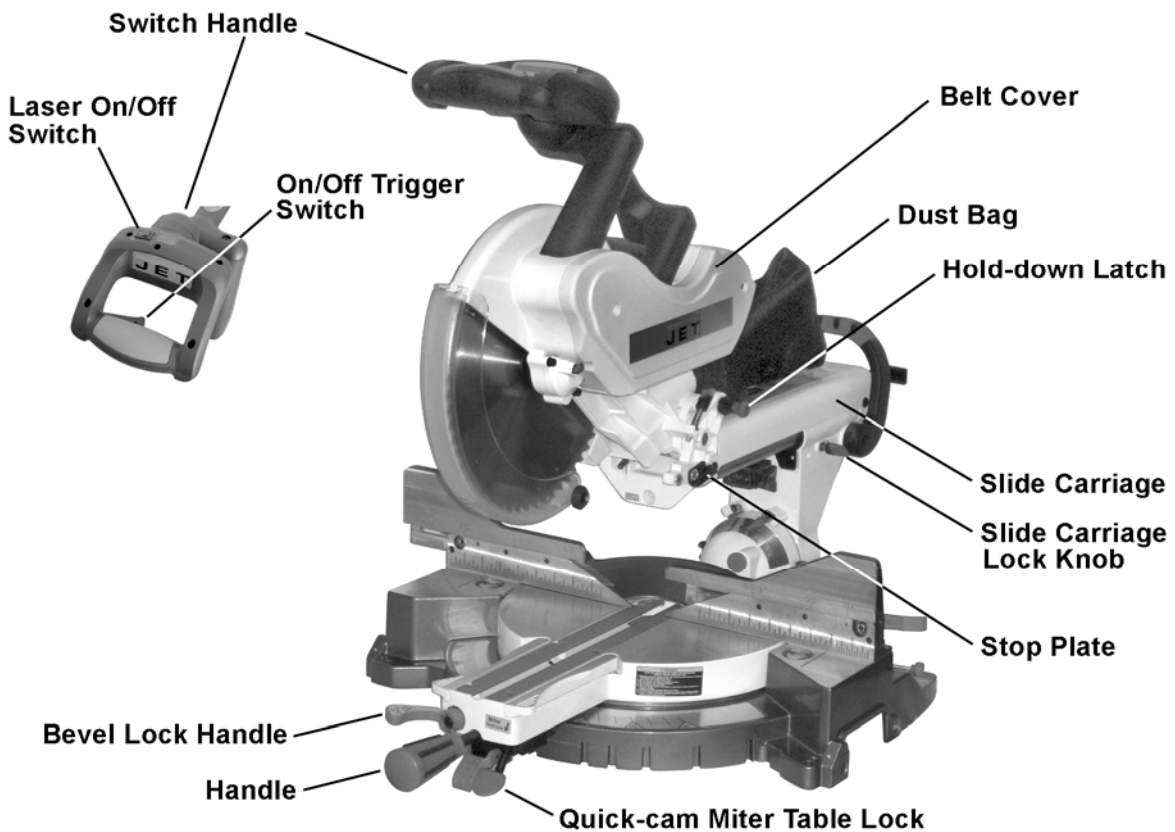
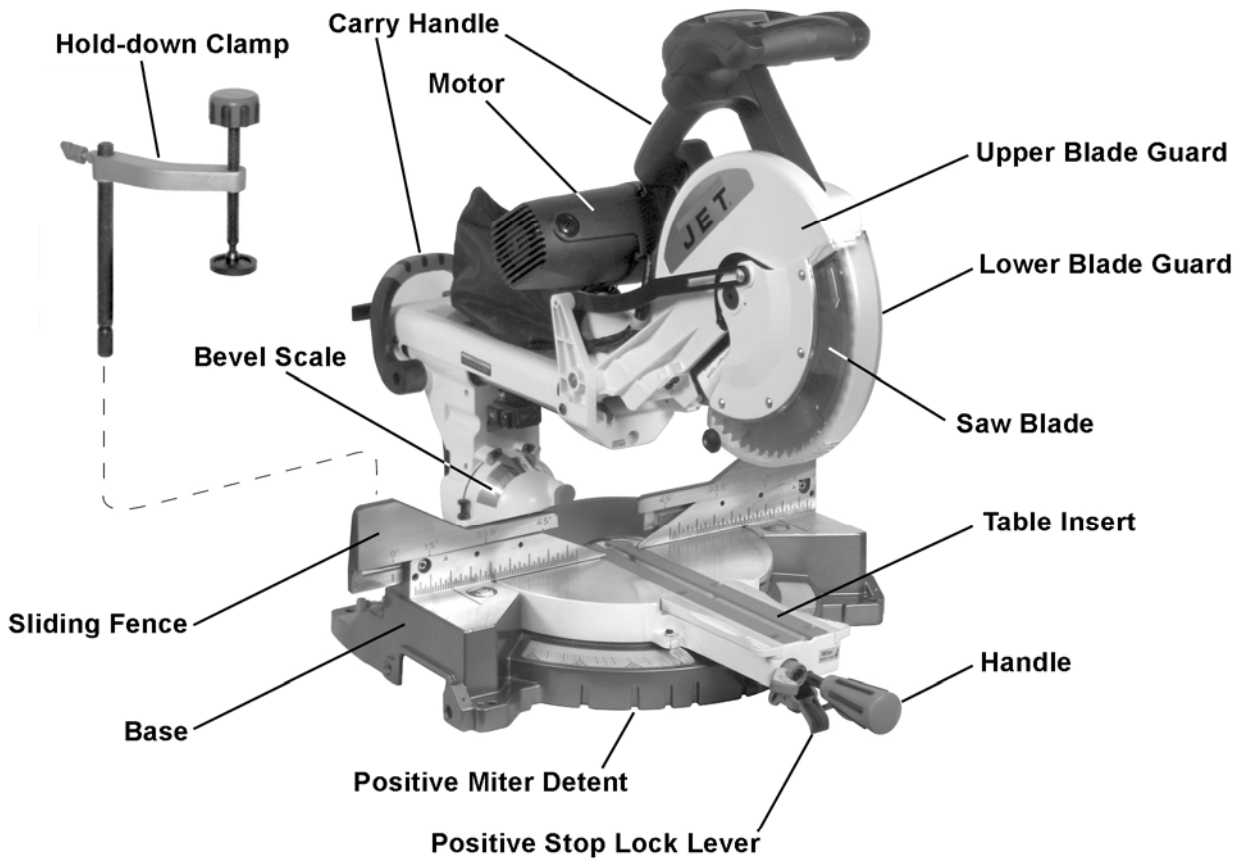

Shipping Contents

Unpacking

1. Remove the contents from the shipping container.
2. Compare the contents of the shipping container with the list found below. Make certain that all items are accounted for before discarding any packing material. Report any shortages or damage to your JET distributor.

Contents of the Shipping Container

- A Compound Miter Saw (1)
- B Dust Bag (1)
- C Power Cord Storage Clip (2)
- D Screw (2)
- E Hold-down Clamp (1)
- F Lock Knob (2)
- Owner's Manual (1)
- Warranty Registration Card

Tools Supplied for Assembly

- G Blade Wrench

Tools not included

- Adjustable Wrench
- 6mm Hex Wrench
- Crosspoint Screwdriver
- Slotted Screwdriver
- Combination Wrench

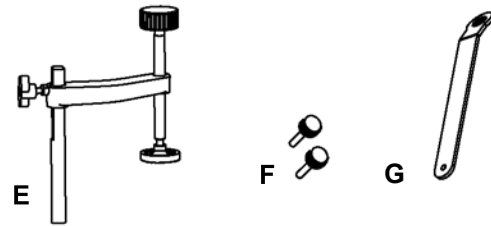
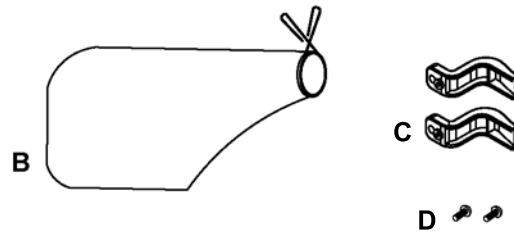
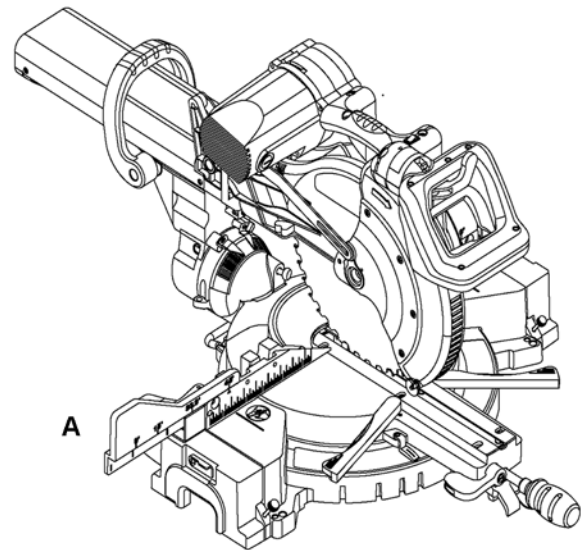

Contents of Shipping Container

⚠ WARNING Read and understand all assembly instructions before attempting assembly! Failure to comply may cause serious injury!

Assembly

Unlocking the Slide Carriage

Loosen the slide carriage *lock knob* (A).

When transporting or storing the miter saw, the *slide carriage* (B) should always be locked in position.

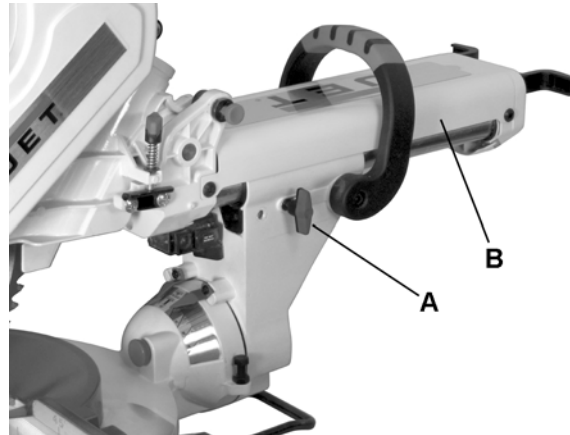

Figure 1

Releasing the Cutting Head

⚠️WARNING When not in use, lock the cutting head in the down position. Failure to comply can cause serious injury or damage equipment.

Unlocking

1. Push down on the *switch handle* (page 10).
2. Pull out the *hold-down latch* (A, Fig. 2).
3. Raise the cutting head to the up position.

Locking

Note: When not in use, lock the cutting head in the down position.

1. Push the cutting head down
2. Press the *hold-down latch* (A, Fig. 2) *in* to lock.

Important: Always use the carrying handles when lifting or moving to avoid damage to the machine.

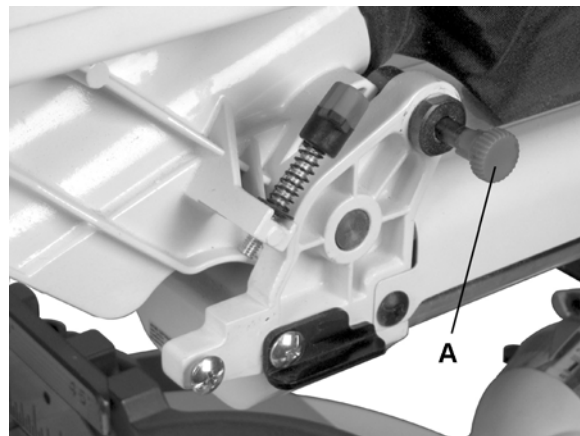

Figure 2

Installing the Dust Bag

1. Squeeze the metal *collar wings* (B, Fig. 3) of the dust bag (A, Fig. 3).
2. Place the dust bag neck opening around the exhaust port (C, Fig. 3), and release the *collar wings* (B).

To empty the dust bag, remove from exhaust port, open zipper on underside of bag and empty into waste container.

Note: Check and empty bag frequently. Do not wait for it to get full.

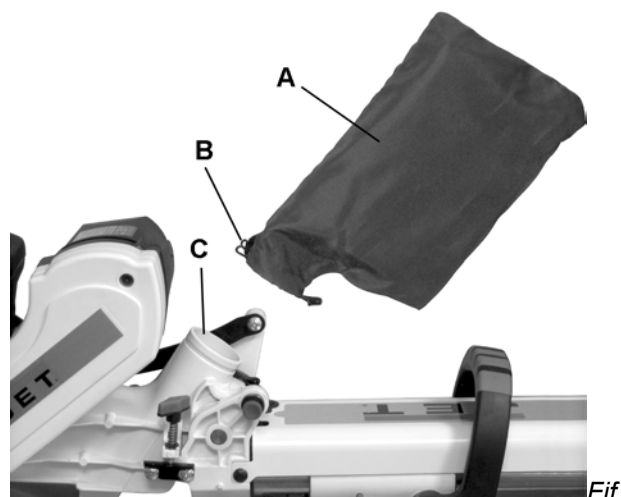

Figure 3

Installing the Safety Hold-down Clamp

1. Place the *hold-down clamp assembly* (A, Fig. 4) in a mounting hole located behind the right or left *fence* (B, C).
2. Thread the *hold-down clamp knob* (D) into the hole located at the rear of the saw base.
3. Tighten the *hold-down clamp knob* (D).

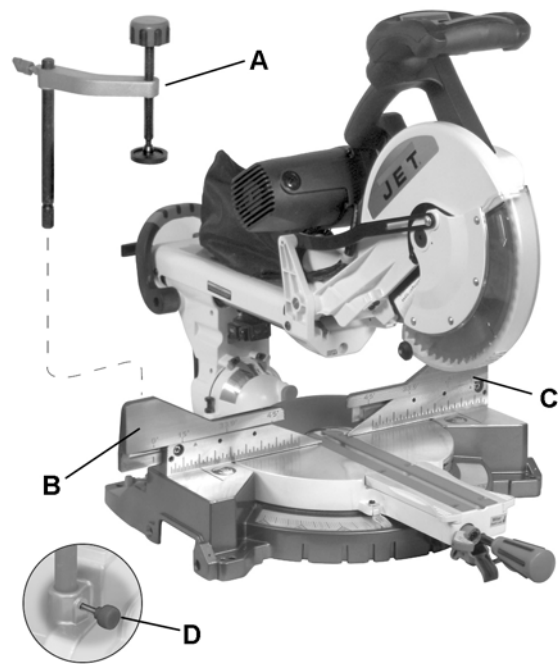

Figure 4

Power Cord Storage Clips

The slide carriage has two clips on the rear for cord storage when the machine is not in use.

To assemble:

Attach each *storage clip* (A, Fig. 5) to the rear of slide-bar seat (C) with one *mounting screw* (B).

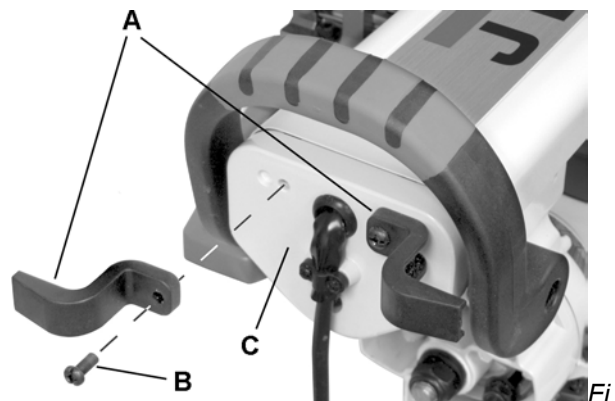

Figure 5

Saw Blade Wrench

For convenience, *storage clip* (A, Fig. 6) is located at the left rear foot of the base for storing the *blade wrench* (B).

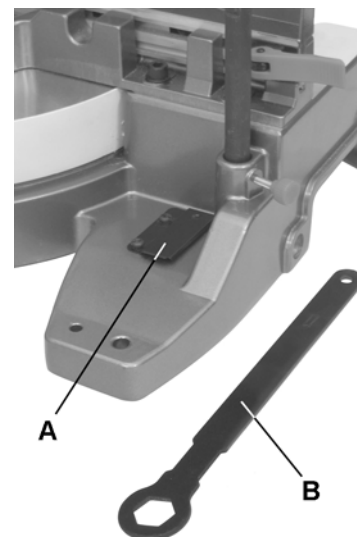

Figure 6

Table Inserts

⚠WARNING Always unplug the saw to avoid accidental starting. Failure to comply may cause serious injury!

- ❑ Remove table insert to remove all small pieces of debris from the table cavity before performing any cuts.
- ❑ Be sure to reattach the table insert prior to performing a cutting operation.

⚠WARNING Do not start the saw without checking for interference between the blade and table insert.

Damage could result to the blade, table insert or turntable if blade strike occurs during the cutting operation.

To remove:

1. Loosen and remove six screws on the *table inserts* (see page 10) with a crosspoint screwdriver
2. Remove the inserts.

To install:

3. Reposition the table inserts.
4. Install the six screws and tighten.

Check for blade clearance by moving the slide carriage through the full motion of the blade in the table slot.

Mounting the Saw

Observe the following safety measures to avoid injury from unexpected saw movement:

- Disconnect the power cord and lock the cutting head in the lower position.
- Lock the slide carriage in place.

When lifting:

- Use the carrying handles on the top of the saw.
- Bend at the knees, not from the back.
- Clamp or bolt the saw on a level work surface.

For stationary use:

Select a location for the saw, such as the top of a workbench, making sure to provide sufficient room for handling the workpiece. Secure the saw to the bench

Mounting hardware is not included and must be purchased separately.

For portable use:

Place the saw on a 3/4 in. thick piece of plywood and bolt the base securely to the plywood using the mounting holes on the base. Mounting hardware is not included and must be purchased separately.

Use C-clamps to clamp this mounting board to a stable work surface at the worksite.

Removing the Blade

⚠WARNING Disconnect power and make sure the switch is in the OFF position to avoid accidental starts. Failure to comply may cause serious injury!

Referring to Figure 7:

1. Unplug the saw from the outlet.
2. Raise the miter saw to the upright position.
3. Raise the lower *clear plastic blade guard* (A) to the uppermost position.
4. While holding the lower blade guard, loosen the *cover plate screw* (C) with a crosspoint screwdriver.
5. Rotate the *cover plate* (B) to expose the *arbor bolt* (H).
6. Place the *blade wrench* over the *arbor bolt* (H).
7. Locate the *arbor lock* (E) on the motor, below the *belt cover* (D).
8. Press the arbor lock, holding it in firmly while turning the blade clockwise. The arbor lock will then engage and lock the arbor. Continue to hold the arbor lock, while turning the wrench clockwise to loosen the arbor bolt.
9. Remove the *arbor bolt* (H), *arbor collar* (G), and blade (J). Do not remove the inner blade collar.
10. Raise the lower *clear plastic blade guard* (A) to the upright position to remove the blade.

Note: Pay attention to the pieces removed, noting their position and direction they face. Wipe the blade collars clean of any sawdust before installing a new blade. Also, the 12 in. blade has a 1 in. arbor hole with a 5/8 in. reducer (F) to mount onto the saw.

Installing Blade

Important: This machine requires a 12-inch diameter blade.

Unplug the miter saw before changing and/or installing the blade.

Referring to Figure 7:

1. Install a 12 in. blade with a 5/8 in. arbor (or a 1 in. arbor with a 5/8 in. reducer) making sure the rotation arrow on the blade matches the clockwise rotation arrow on the upper guard, and the blade teeth are pointing downward.
2. Place the *arbor collar* (G) against the blade and on the arbor. Thread the *arbor bolt* (H) on the arbor in a counterclockwise direction.

Important: Make sure that the flat edge inside the blade collar opening is aligned with the flat edge on the arbor shaft. Also, the flat -side of the *arbor collar* (G) must be placed against the *blade* (J).

3. Place the blade wrench on the *arbor bolt* (H).
4. Press the *arbor lock* (E), holding it in firmly while turning the blade counterclockwise (opposite the cutting direction of the blade). When it engages, continue to press the *arbor lock* (E) in, while tightening the *arbor bolt* (H) securely.
5. Rotate the *cover plate* (B) back to its original position until the slot in the cover plate engages with the *cover plate screw* (C). While holding the *lower blade guard* (A) up as shown, tighten the *screw* (C) with a cross-point screwdriver.
6. Lower the *retractable blade guard* (A) and verify that the operation of the guard does not bind or stick.
7. Turn the blade to disengage the *arbor lock* (E); then verify that the blade will spin freely.

WARNING Never use the saw without the cover plate secure in place. Failure to comply may cause serious injury!

The cover plate keeps the arbor bolt from falling out if it accidentally loosens, and helps prevent the spinning blade from coming off the saw.

WARNING Verify that the collars are clean and properly installed. Lower the blade into the table and verify that it does not come in contact with the metal base or the turn table. Failure to comply may cause serious injury!

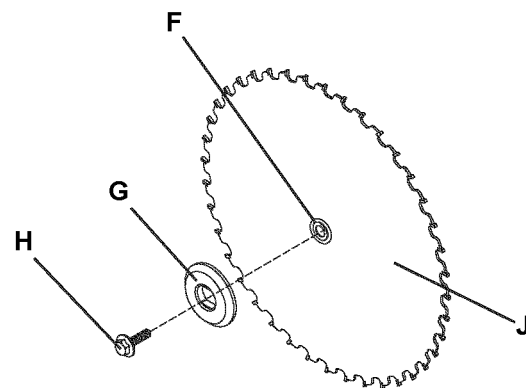
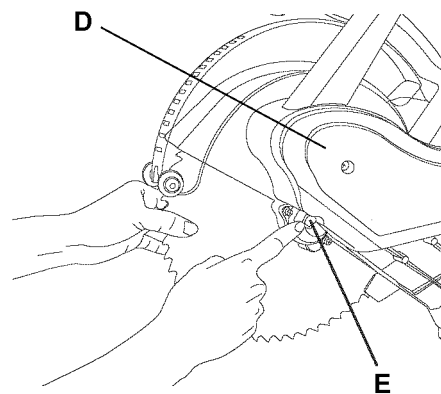
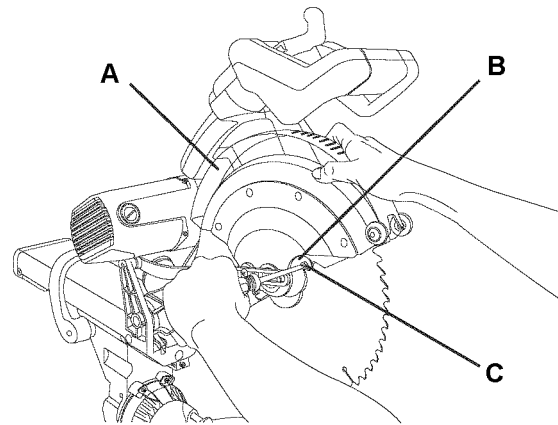

Figure 7

Adjustments

⚠WARNING Before attempting any adjustments – To avoid injury from unexpected starting or electrical shock make sure the trigger is released and remove the power cord from the power source. Failure to comply may cause serious injury!

Note: Your miter saw was adjusted at the factory. However, during shipment slight misalignment may have occurred. Check the following settings and adjust if necessary prior to using this miter saw.

Bevel Stop Adjustments

90°(0°) Bevel Adjustment

1. Turn the *bevel lock handle* (A, Fig. 8) clockwise to loosen and tilt the cutting arm while pushing the *bevel detent pin* (E, Fig. 10) in against the 0° bevel stop. Turn the *bevel lock handle* (A, Fig. 8) counterclockwise to tighten.
2. Place a combination square on the miter table with the rule against the table and heel of the square against the saw blade.

If the blade is not 0° to the miter table:

3. Using a 5mm hex wrench, loosen four *adjustment bolts* (B, Fig. 9) at the back of the miter saw. Unlock the *bevel lock handle* (A, Fig. 8) and position the cutting arm to be zero degrees to the table using the combination square as your reference.
4. Tighten the *bevel lock handle* (A, Fig. 8) and the four *adjustment bolts* (B, Fig. 9).

Bevel Scale Indicators

1. Set the blade to be exactly 90°(0°) to the table.
2. With cross-point screwdriver, loosen two *bevel indicator screws* (C, Fig. 9).
3. Adjust *bevel indicators* (D, Fig. 9) to the “0” mark on the bevel scale and retighten the screws (C, Fig. 9).

45° Left Bevel Positive Stop Adjustment

1. Set the miter angle to zero degrees. Fully extend the sliding fence completely to the left then pull the *bevel detent pin* (E, Fig. 10) out.

Note: When retracting the bevel detent pin, it may be required to slightly shift the upper arm assembly right or left.

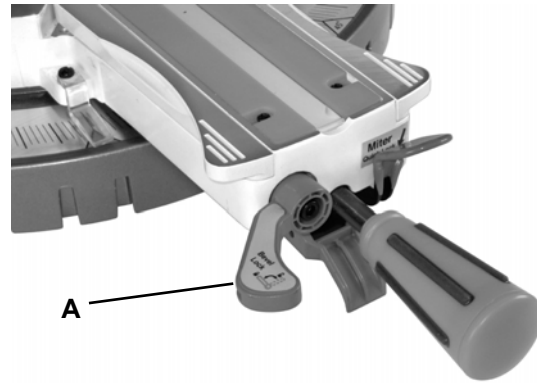

Figure 8

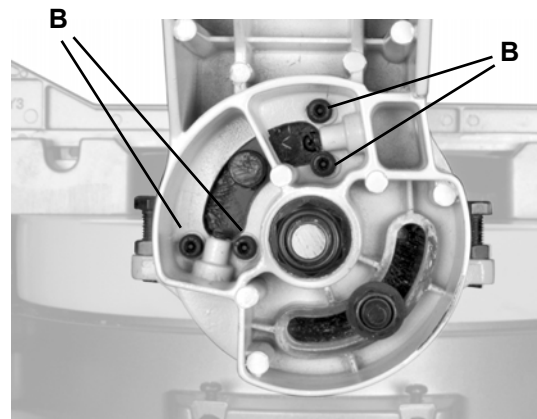

Figure 9

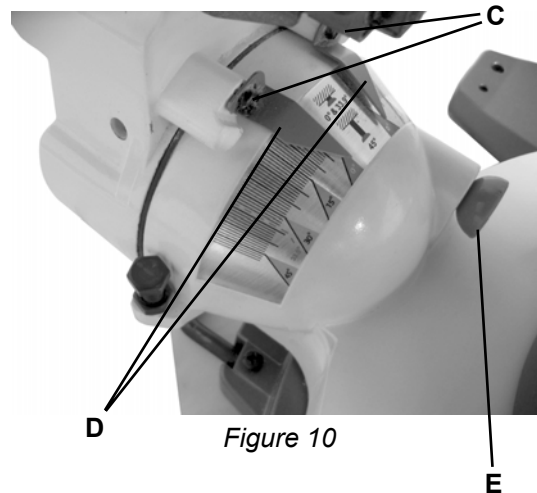

Figure 10

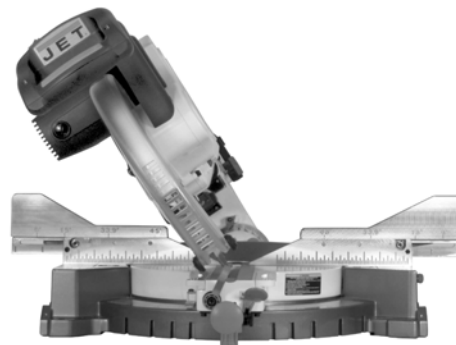

Figure 11

2. Loosen the *bevel lock handle* (A, Fig. 8) and tilt the cutting arm completely to the left (Figure 11).
3. Using a combination square, check to see if the blade is 45° to the table.
4. To adjust, tilt the cutting arm to zero degrees, loosen the *lock nut* (B, Fig. 12) and turn the *stop bolt* (A, Fig. 12) in or out accordingly.
5. Tilt the cutting arm back to the left and recheck alignment.
6. Repeat steps 1–4 if necessary until the blade is 45° to the table, then tighten the *lock nut* (B, Fig. 12) to secure the *stop bolt* (A, Fig. 12).



Figure 12

45° Right Bevel Positive Stop Adjustment

1. Set the miter angle to zero degrees. Fully extend the sliding fence completely to the right then pull the bevel detent pin (E, Fig. 12) out.

Note: When retracting the bevel detent pin, it may be required to slightly shift the upper arm assembly right or left.

2. Loosen the *bevel lock handle* (A, Fig. 8) and tilt the cutting arm completely to the right (Figure 13).
3. Using a combination square, check to see if the blade is 45° to the table.
4. To adjust, tilt the cutting arm to zero degrees, loosen the locknut (D, Fig. 12) and turn the *stop bolt* (C, Fig. 12) in or out accordingly.
5. Tilt the cutting arm back to the right and recheck alignment.
6. Repeat steps 1–4 if necessary until the blade is 45° to the table, then tighten the *lock nut* (D, Fig. 12) to secure the *stop bolt* (C, Fig. 12).

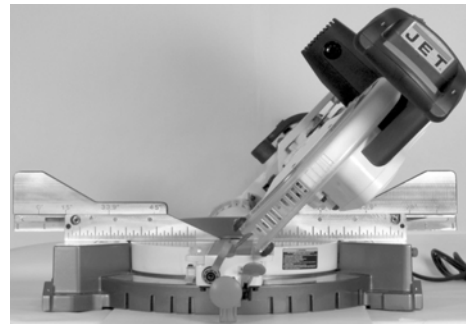

Figure 13

33.9° Left & Right Bevel Adjustment

1. Set the miter angle to zero degree. Fully extend both sliding fences.
2. Loosen the *bevel lock handle* (A, Fig. 8).
3. Tilt the cutting arm to the 33.9° left bevel position and engage the positive stop by pushing the *bevel detent pin* (E, Fig. 12) in.
4. Using a combination square, check to see if the blade is 33.9° to the table.
5. To adjust, turn the *setscrew* (A, Fig. 14) in or out with a 6mm hex wrench until the blade is 33.9° to the table.
6. Repeat steps for the right bevel 33.9° bevel adjustment, making adjustments to setscrew B, Fig. 15.

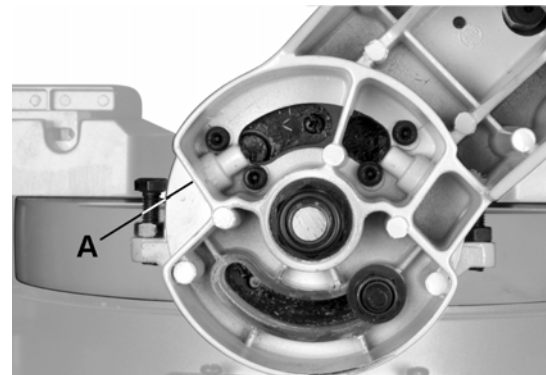

Figure 14

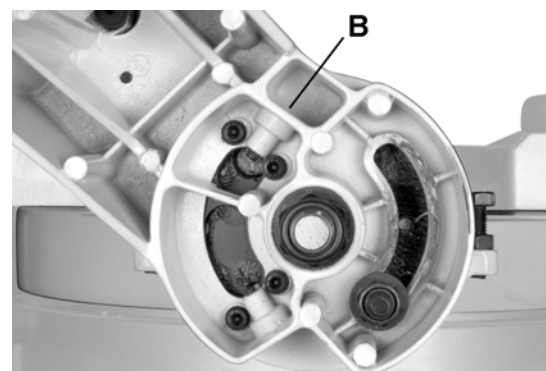

Figure 15

Miter Angle

The sliding compound miter saw scale can be easily read, showing miter angles from 0° to 45° to the left, and 0° to 60° to the right. The miter saw table has ten of the most common angle settings with positive stops at 0°, 15°, 22.5°, 31.6°, and 45° and 60° right. These positive stops position the blade at the desired angle quickly and accurately. Follow the process below for quickest and most accurate adjustments.

Referring to Figure 16:

1. Lift up on the quick-cam *miter table lock* (A) to unlock the table.
2. Lift up on the *positive stop locking lever* (C) and move the turntable with *handle* (B) to align the *indicator* (D) to the desired degree measurement.
3. Lock the table into position by pressing down on the quick-cam *miter table lock* (A).

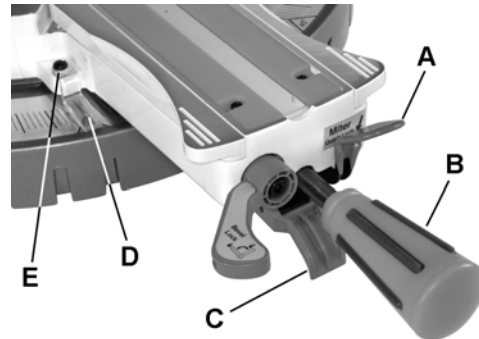

Figure 16

Miter Scale Indicator Adjustment

4. Move the table to the 0° positive stop.
5. Loosen the screw (E) that holds the indicator with a screwdriver.
6. Adjust the *indicator* (D) to the 0° mark and retighten screw.

Adjusting Fence Squareness

1. Loosen four *fence locking screws* (D, Fig. 18).
Note: two locking screws to each fence.
2. Lower the cutting arm and lock in position.
3. Using a *square* (B, Fig. 17), lay the heel of the square against the *fence* (C, Fig. 17) and the ruler against the *blade* (A, Fig. 17).
4. Adjust the fence 90° to the blade and tighten the four fence locking screws.

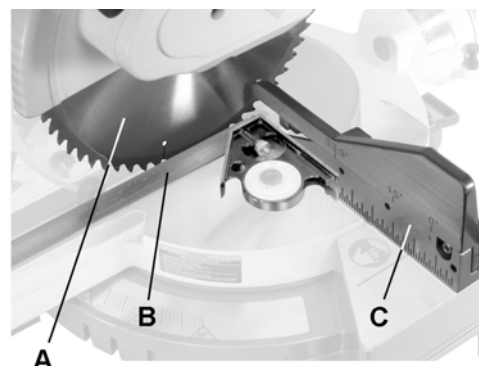

Figure 17

CAUTION If the saw has not been used recently, recheck blade squareness to the fence and readjust if needed.

5. After fence has been aligned, using a scrap piece of wood, make a cut at 90° then check squareness on the piece. Readjust if necessary.

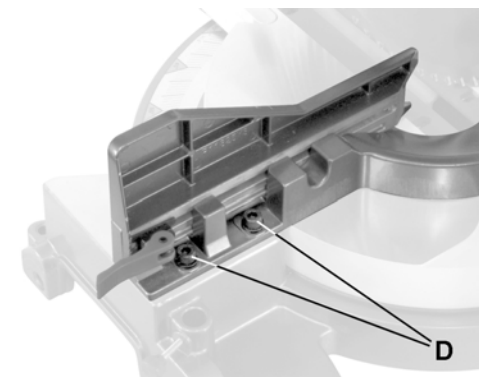

Figure 18

Positive Stop Miter Angle Adjustment

Referring to Figure 19:

1. Unlock the miter table by lifting up on the quick-cam *miter table lock* (A).
2. Raise the *positive stop locking lever* (C) up; at the same time grasp the *miter handle* (B) and rotate the miter table left or right to the desired angle.
3. Release the *positive stop locking lever* (C) and set the miter at the desired angle making sure the lever snaps into place.

Note: There are ten positive stops into which the lever will lock.

4. After the angle is selected, press down on the quick-cam *miter table lock* (A).

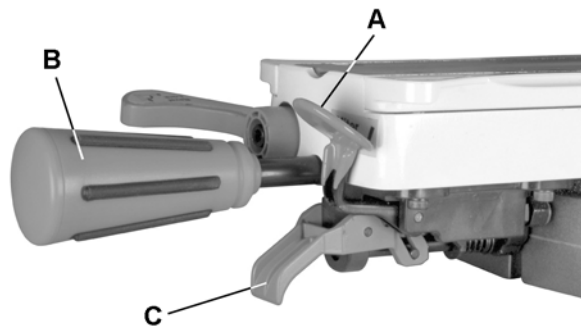

Figure 19

Quick-cam Miter Table Lock Operation

If a miter angle required is not one of ten positive stops, the miter table can be locked at any angle between these positive stops by using the quick-cam miter table lock.

Referring to Figure 19:

1. Unlock the miter table by lifting up on the quick-cam *miter table lock* (A).
2. Raise the *positive stop locking lever* (C) up; at the same time grasp the *miter handle* (B) and rotate the miter table left or right to the desired angle.
3. Release the positive stop locking lever (C).
4. Press down on the quick-cam *miter table lock* (A) until it locks the miter table in place.

Note: The quick-cam miter table lock should lock the table and prevent it from moving. If adjustment is needed, see *Quick-cam Miter Table Lock Adjustment* below.

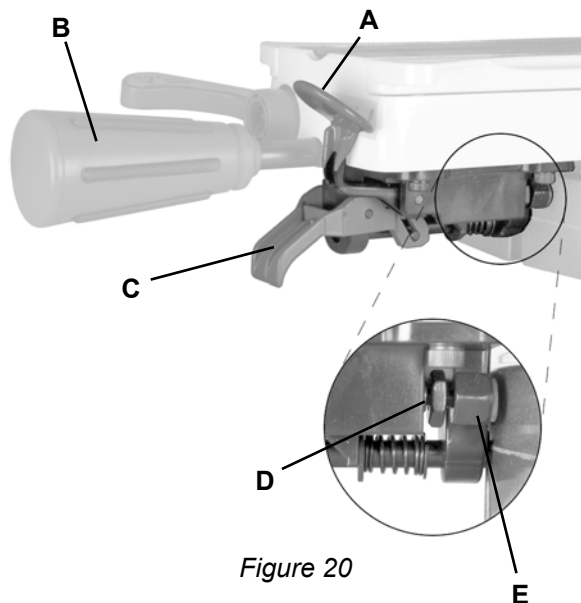

Figure 20

Quick-cam Miter Table Lock Adjustment

Referring to Figure 20:

1. Place the quick-cam *miter lock* (A) in the down position to lock.
2. Loosen the *lock nut* (D) with a 13 mm wrench, then turn the stop nut (E) to extend the locking arm against the base of the miter saw.
3. Test the quick-cam *miter lock* (A) to verify that it locks the table securely into position.
4. Tighten the *lock nut* (D) to lock the miter locking mechanism into place.

Presetting the Cutting Depth

The depth of cut can be preset for even and repetitive shallow cuts.

Referring to Figure 21:

1. Pull *hold-down latch* (C) out.
2. Flip the *stop plate* (A) counterclockwise to the left.
3. Adjust the cutting head down (See *Cutting Head* section) until the teeth of the blade are at the desired depth.
4. While maintaining the cutting head in the desired position, turn the *stop knob* (B) until it touches the *stop plate* (A).
5. Recheck the blade depth by moving the cutting head front to back through the full motion of a typical cut along the control arm.

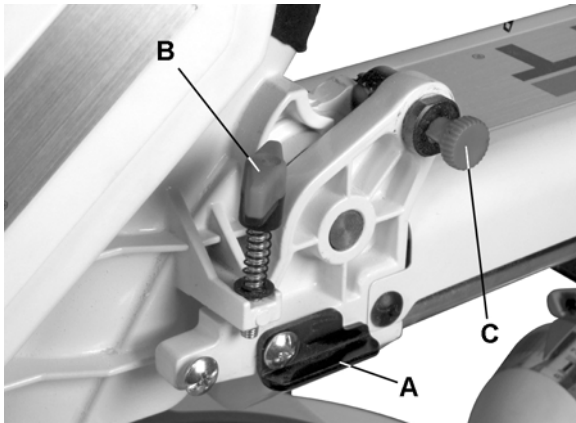

Figure 21

Rear Support Bar

WARNING Do not operate the saw without the rear extension support bar. Failure to comply may result in serious injury!

Loosen the two screws (A, Fig. 22) and extend the rear extension support bar (B, Fig. 22) by sliding it out, then tighten the two screws.

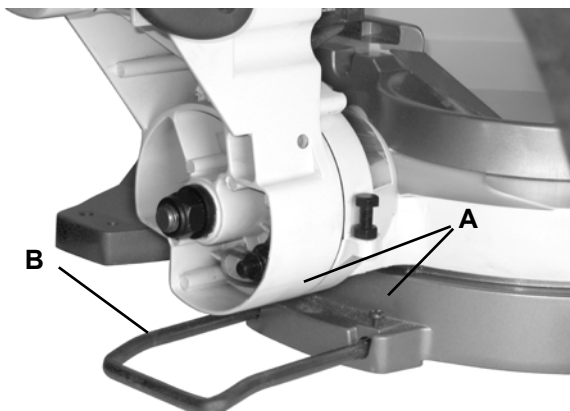

Figure 22

Laser Beam

The laser is turned on with a switch located on the saw handle (C, Fig. 23). When left on indefinitely, a sensor will turn the laser off after 20 minutes. The switch must be reset (turned off for two seconds, then on again) to restart.

The laser has no adjustments and should not require adjustment. If adjustment should become necessary, take the miter saw to an approved service center.

- **Laser radiation. Avoid direct eye exposure. Always un-plug miter saw from power source before making any adjustments.**
- **Laser Warning Label: Max output <1mW DIODE LASER: 522-542nm, Complies with 21CFR 1040.10 and 1040.11.**



CAUTION Use of controls or adjustments or performance of procedures other than those specified in this manual may result in hazardous radiation exposure.

CAUTION The use of optical instruments with this product will increase eye hazard.

- Do not attempt to repair or disassemble the laser. If unqualified persons attempt to repair this laser product, serious injury may result. Any repair required on this laser product should be performed by authorized service center personnel.

Operation

⚠WARNING Before attempting any operation with your miter saw, make sure that you have read and thoroughly understand the warnings contained on pages 5-6 and the *Compound Miter Saw Safety* section on page 7. Failure to comply may result in serious injury!

Starting a cut

1. Place hands at least 8-3/4 in. away from the path of the blade.
2. Hold workpiece firmly against the fence to prevent movement toward the blade.
3. Bring the saw blade down to the workpiece to see the cutting path of the blade.
4. Squeeze the *trigger switch* (A, Fig. 23) to start saw.
5. Lower blade into workpiece with a firm downward motion.

Finishing a cut

1. Hold the cutting arm in the down position.
2. Release trigger switch (A, Fig. 23) and wait for all moving parts to stop before moving your hands and raising the cutting arm.
3. If the blade does not stop within 10 seconds, unplug the saw and follow the instructions in the *Troubleshooting* section.

Jammed Material

1. Release trigger switch.
2. Wait for all moving parts to stop.
3. Unplug the miter saw.

To Turn the Saw On

Depress the trigger switch (A, Fig. 23).

Note: Make the On/Off switch child-proof by inserting a padlock through the hole (B, Fig. 23) in the trigger switch.

The miter saw is equipped with an automatic blade brake. When the trigger switch is released, the electric blade brake will stop the blade within approximately 10 seconds.

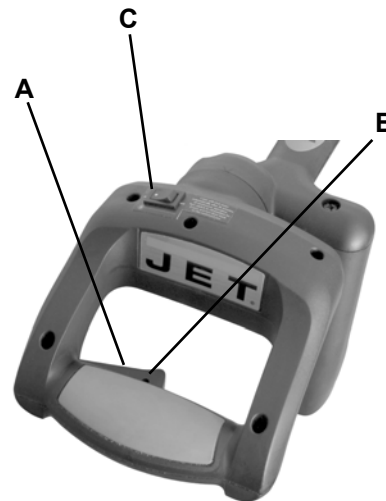

Figure 23

Sliding Fence

⚠WARNING The sliding fence must be extended to the left or right when making bevel cuts. Failure to comply may cause serious injury!

Failure to extend the sliding fence will not allow enough space for the blade to pass through. This could result in serious injury. At extreme miter or bevel angles the saw blade may also contact the fence resulting in damage to equipment as well as personal injury.

The right side sliding fence must be removed when making any right bevel angle cuts greater than 35° in combination with any right hand miter angle. This fence must also be removed whenever a 45° bevel angle is desired with a miter angle greater than 22.5°.

To adjust the sliding fence (refer to Figure 24):

1. Unlock the *fence cam locking lever* (A) (shown locked in Figure 24) by pushing it toward the rear of the machine.
2. Extend the *fence* (B) by sliding it out (C) to match the degree of the bevel cut. Lock the *fence cam locking lever* (A) as shown.

Note: Secure the sliding fence in position closest to the saw blade when transporting the saw.

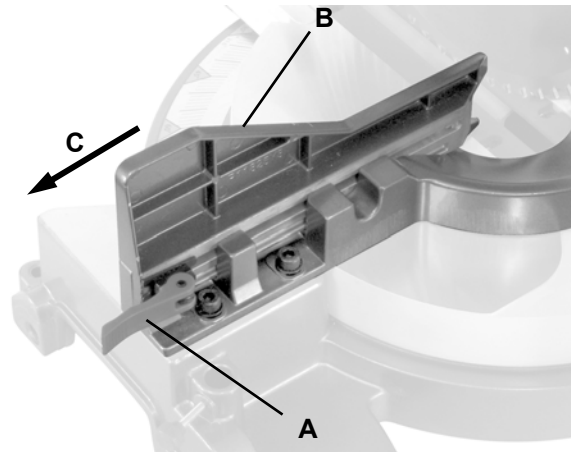

Figure 24

Removing or Installing the Sliding Fence

Removing

1. Unlock the *fence cam locking lever* (A, Fig. 24 shows the locked position).
2. Lift up on the sliding fence to remove.

Installing

1. Place the sliding fence onto the miter saw fence making sure to align the nut on the sliding fence with the slot in the stationary fence.
2. Lock the sliding fence by push the cam-locking lever *in* as shown (A, Fig. 24)

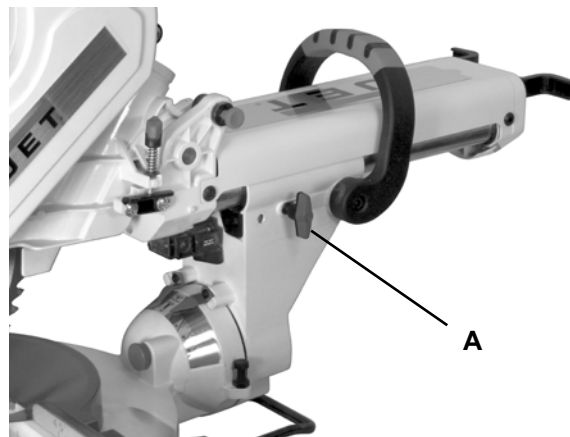

Figure 25

Sliding Carriage System

⚠WARNING To reduce the risk of injury, return carriage to the full rear position after each crosscut operation.

- ❑ For a chop cutting operations on small workpieces, slide the cutting head assembly completely toward the rear of the unit and tighten the *carriage lock knob* (A, Fig. 25).
- ❑ To cut wide boards up to 12-1/4 in., the *carriage lock knob* (A, Fig. 25) should be loosened to allow the cutting head to slide freely.

⚠WARNING To avoid injury from materials being thrown, always unplug the saw to avoid accidental starting, and remove small pieces of material from the table cavity. The table insert may be removed for this purpose, but always reattach the table insert prior to performing a cutting operation.

Miter Cut

Referring to Figure 26:

The sliding compound miter saw has ten positive miter stop indents (A) located on the saw base. The stops represent the following miter cut angles: 0, 15, 22.5, 31.6 and 45 degrees left and right, and 60° right. To make a miter cut:

1. Unlock the miter table by lifting up on the quick-cam *miter table lock* (E).
2. Raise the *positive stop locking lever* (C) up, at the same time grasp the *miter handle* (D) and rotate the miter table left or right to the desired angle.
3. Release the *positive stop locking lever* (C), making sure the lever snaps into place at one of the miter stop indent (A).

Note: The lever will only lock into place at one of the ten positive stops indicated above

Once the desired miter angle is achieved:

4. Press down on the quick cam *miter table lock* (E) to secure the table into position.

If the miter angle desired is *not* one of the ten positive stops noted above:

5. Simply lock the table at the desired angle by pressing down on the quick-cam *miter table lock* (E).

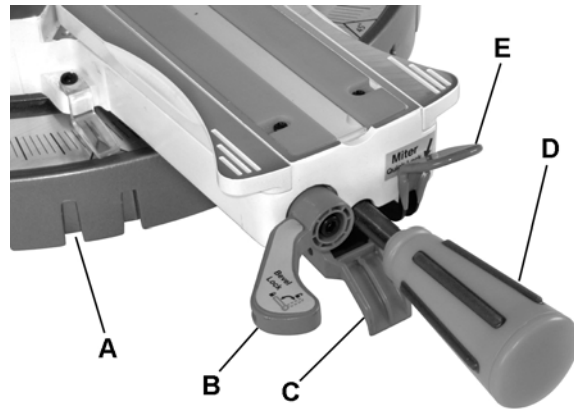

Figure 26

Bevel Cut

⚠WARNING The sliding fence must be extended to the left or right when making bevel cuts. Failure to comply may cause serious injury!

Failure to extend the sliding fence will not allow enough space for the blade to pass through. This could result in serious injury. At extreme miter or bevel angles the saw blade may also contact the fence resulting in damage to equipment as well as personal injury.

The right side sliding fence must be removed when making any right bevel angle cuts greater than 35° in combination with any right hand miter angle. This fence must also be removed whenever a 45° bevel angle is desired with a miter angle greater than 22.5°.

Tilt the cutting head to the desired angle as shown on the bevel scale. The blade can be positioned at any angle, from a 90° straight cut (0° on the scale) to a 45° left and right bevel. Tighten the *bevel lock handle* (B, Fig. 26) by pushing down to lock the cutting head in position. Bevel positive stops are provided at 0°, 33.9° and 45°.

Note: The saw comes with a 33.9° bevel detent pin for setting up crown molding cuts when the angle of the walls equals 90°.

33.9° Bevel Detent Pin for Crown Moldings

Note: A bevel detent pin is incorporated into this machine for quick bevel adjustments when the desired bevel angle is 33.9°.

Referring to Figure 27 (except where indicated):

1. Push the *bevel detent stop pin* (E) in.
2. Loosen the *bevel lock handle* (A).
3. Rotate the *cutting head* (D, Fig. 28) until the *bevel detent pin* (E) stops the bevel angle at 33.9° on the *bevel scale* (F).
4. Tighten the *bevel lock handle* (A) before you make your cut.

Compound Cuts

Referring to Figure 27:

Setting the bevel angle

1. Extend the fence by sliding it out to the required location or remove the right sliding fence if necessary. (See *Sliding Fence* or *Removing or Installing the Sliding Fence* on page 22).
2. Loosen the *bevel lock handle* (A).
3. Set the desired bevel angle; then lock the *bevel lock handle* (A).

Setting the miter angle

4. Set the desired miter angle and lock into position. See *Miter Cut*.
5. Unlock the miter table by lifting up on the quick-cam *miter table lock* (D).
6. Raise the *positive stop locking lever* (C) up, at the same time grasp the *miter handle* (B) and rotate the miter table left or right to the desired angle.
7. Release the *positive stop locking lever* (C).
8. Lock the miter table by pressing down on the quick-cam *miter table lock* (D).

90° Crosscut – Narrow Boards

For 90° crosscut operations on small workpieces (refer to Figure 29):

1. Slide the cutting head assembly completely toward the rear of the unit and tighten the *carriage lock knob* (F).
2. Position the cutting head to the 0° bevel position and lock the *bevel lock handle* (C).
3. Position the table to the 0° miter angle and lock the quick cam *miter table lock* (D).

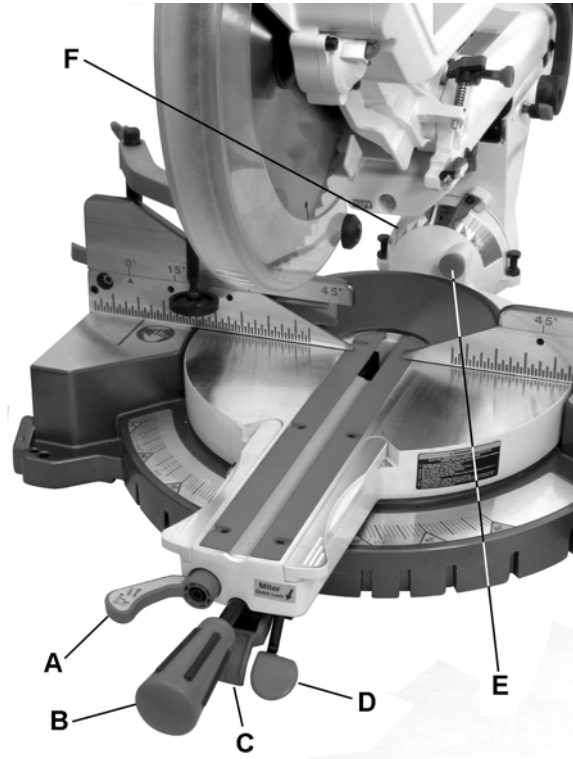

Figure 27

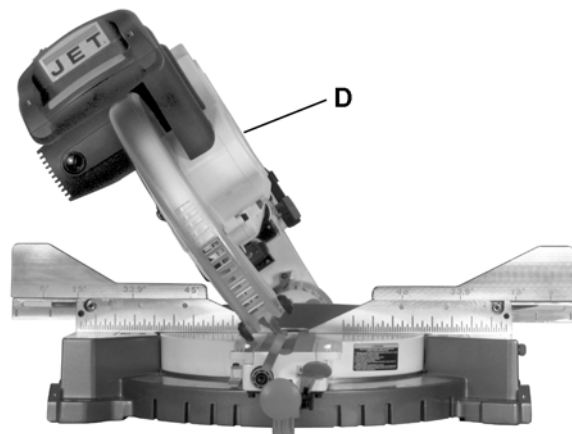

Figure 28

4. Position the workpiece on the table and against the fence. Use a *hold-down clamp* (E) attached to the base, whenever possible.
5. Pull the *trigger* (A), turning on the saw. Lower the blade by pushing the *handle* (B) down into the workpiece with slow and even pressure.
6. When the cut is complete, release the switch and allow the blade to stop before raising the cutting head assembly.

Slide Cutting Wide Boards

▲WARNING Observe the following precautions:

- ❑ Never pull the cutting head assembly and spinning blade toward you during the cut.
- ❑ Let the blade reach full speed before cutting.
- ❑ Extending the fence by sliding it out to the required location or
- ❑ Remove the right sliding fence if necessary.

Failure to comply may cause serious injury!

Use this operation to crosscut boards up to 12-1/4 inches wide.

Referring to Figure 30:

1. Unlock the *carriage lock knob* (D).
2. Set both the desired bevel angle and/or the miter angle as described in *Compound Cuts* (page 24); then lock into position.
3. If bevel cutting, set both the left and right sliding fences (C) to their proper location.
4. Use a hold down clamp to secure the workpiece.
5. Grasp the *switch handle* (F) and pull the *carriage* (A) forward until the center of the saw blade is over the front of the *workpiece* (B).
6. Pull the *trigger* (E) to turn the saw on.
7. When the saw reaches full speed, push the *saw handle* (F) down slowly, cutting through the leading edge of the workpiece.
8. Slowly move the *saw handle* (F) toward the *fence* (C) to complete the cut.
9. Release the *trigger* (E) and allow the blade to stop spinning before allowing the cutting head to raise.

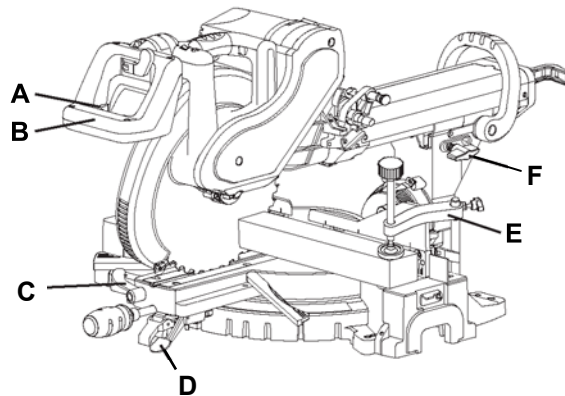

Figure 29

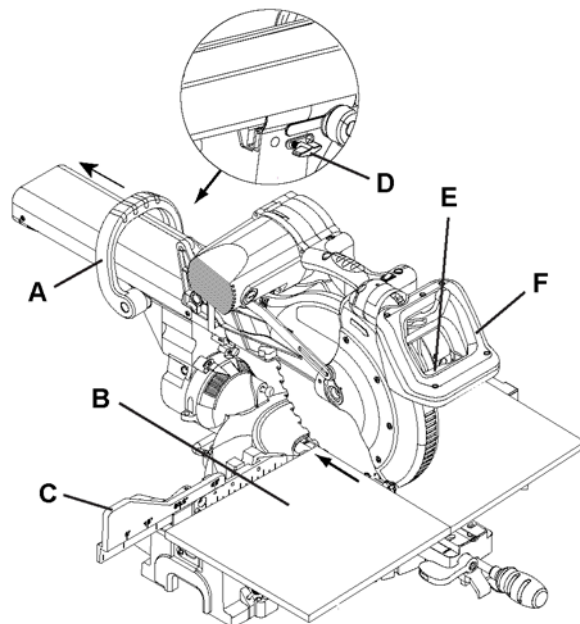

Figure 30

Cutting Bowed Material

⚠WARNING Always unplug the saw when removing small pieces of debris. Failure to comply may cause serious injury!

Referring to Figure 31:

1. Position a curved *workpiece* (C) against the *fence* (B).
2. Secure the curved workpiece with a *clamping device* (A).

Cutting a curved workpiece without the support of the fence and clamping device could result in personal injury.

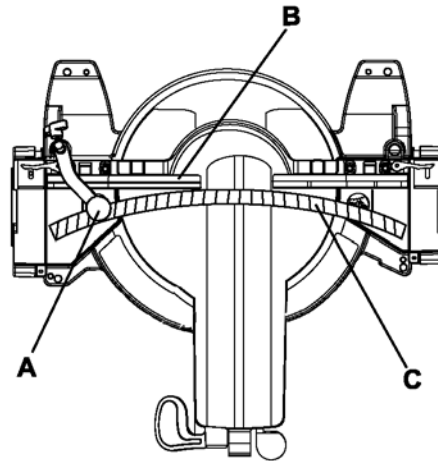

Figure 31

Rough Cutting a Dado

1. Mark lines identifying the width and depth of the desired cut on the workpiece and position on the table so the inside tip of the blade is positioned on the line. Use a hold down clamp to secure the workpiece.
2. Set to the desired cutting depth as described in Presetting the Cutting Depth (page 20).
3. While holding the upper arm in position, turn the *stop knob* (B) until it touches the *stop plate* (A). Note: *Stop plate* (A) must be flipped to the left.
4. Cut two parallel grooves.

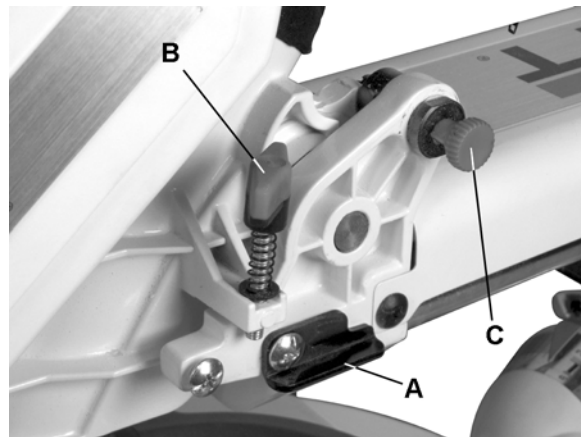

Figure 32

Auxiliary Wood Fence

When making multiple or repetitive cuts that result in cut-off pieces of one inch or less, it is possible for the saw blade to catch the cut-off piece and throw it out of the saw or into the blade guard and housing, possibly causing damage or injury. To minimize this, an auxiliary wood fence can be mounted to your saw. Holes are provided in the saw fence to attach an auxiliary wood fence (this provides additional depth of cut). This fence should be constructed of straight wood approximately 3/4 in. thick by 1-1/2 in. high by 22 in. long. Attach the wood fence securely and make a full depth cut to make a blade slot. Check for interference between the wood fence and the lower blade guard. Adjust if necessary.

Changing the Belt

1. Unplug your saw.
2. Loosen the bolts and remove the belt cover.
3. Turn the screw counterclockwise with a hex wrench to move the motor forward.
4. Remove and replace the belt.
5. Turn the screw clockwise with a hex wrench to move the motor back. Do not over tighten.
6. Replace the belt cover and tighten the bolts.

Cutting Base Molding

Base moldings and many other moldings can be cut on a compound miter saw. The setup of the saw depends on molding characteristics and application. Perform practice cuts on scrap material to achieve best results:

1. Always make sure moldings rest firmly against fence and table. Use hold-down, crown molding vise or C-clamps, whenever possible, and place tape on the area being clamped to avoid marks.
2. Reduce splintering by taping the cut area prior to making the cut. Mark the cut line directly on the tape.
3. Splintering typically happens due to an incorrect blade application and thinness of the material.

Note: Always perform a dry run cut so you can determine if the operation being attempted is possible before power is applied to the saw.

Crown Molding

Your compound miter saw is suited for the difficult task of cutting crown molding. To fit properly, crown molding must be compound-mitered with extreme accuracy. The two surfaces on a piece of crown molding that fit flat against the ceiling and wall are at angles that, *when added together, equal exactly 90°*.

Most crown molding has a top rear angle (the section that fits flat against the ceiling) of 52° and a bottom rear angle (the section that fits flat against the wall) of 38°.

In order to accurately cut crown molding for a 90° inside or outside corner, lay the molding with its broad back surface flat on the saw table.

When setting the bevel and miter angles for compound miters, remember that the settings are interdependent; changing one changes the other, as well.

Bevel/Miter Settings

Settings for standard crown molding lying flat on compound miter saw table.

Note: The chart below references a compound cut for crown molding *only when the angle between the walls equals 90°*.

Type of Cut	Key	Bevel Setting	Miter Setting	Procedure
Inside corner – Left Side	IL	33.9°	31.6° Right	<ol style="list-style-type: none"> 1. Position top of molding against fence. 2. Miter table set at RIGHT 31.6°. 3. LEFT side is finished piece.
Inside corner – Right Side	IR	33.9°	31.6° Left	<ol style="list-style-type: none"> 1. Position bottom of molding against fence. 2. Miter table set at LEFT 31.6°. 3. LEFT side is finished piece.
Outside corner – Left Side	OL	33.9°	31.6° Left	<ol style="list-style-type: none"> 1. Position bottom of molding against fence. 2. Miter table set at LEFT 31.6°. 3. RIGHT side is finished piece.
Outside corner – Right Side	OR	33.9°	31.6° Right	<ol style="list-style-type: none"> 1. Position top of molding against fence. 2. Miter table set at RIGHT 31.6°. 3. RIGHT side is finished piece

Crown Molding Chart

Compound miter saw *miter and bevel angle settings, wall to crown molding angles*

Angle Between Walls	52/38° Crown Molding		45/45° Crown Molding	
	Miter Setting	Bevel Setting	Miter Setting	Bevel Setting
67	42.93	41.08	46.89	36.13
68	42.39	40.79	46.35	35.89
69	41.85	40.50	45.81	35.64
70	41.32	40.20	45.28	35.40
71	40.79	39.90	44.75	35.15
72	40.28	39.61	44.22	34.89
73	39.76	39.30	43.70	34.64
74	39.25	39.00	43.18	35.38
75	38.74	38.69	42.66	34.12
76	38.24	38.39	42.15	33.86
77	37.74	38.08	41.64	33.60
78	37.24	37.76	41.13	33.33
79	36.75	37.45	40.62	33.07
80	36.27	37.13	40.12	32.80
81	35.79	36.81	39.62	32.53
82	35.31	36.49	39.13	32.25
83	34.83	36.17	38.63	31.98
84	34.36	35.85	38.14	31.70
85	33.90	35.52	37.66	31.42
86	33.43	35.19	37.17	31.34
87	32.97	34.86	36.69	30.86
88	32.52	34.53	36.21	30.57
89	32.07	34.20	35.74	30.29
90	31.62	33.86	35.26	30.00
91	31.17	33.53	34.79	29.71
92	30.73	33.19	34.33	29.42
93	30.30	32.86	33.86	29.13
94	29.86	32.51	33.40	28.83
95	29.43	32.17	32.94	28.54
96	29.00	31.82	32.48	28.24
97	28.58	31.48	32.02	27.94
98	28.16	31.13	31.58	27.64
99	27.74	30.78	31.13	27.34
100	27.32	30.43	30.68	27.03
101	26.91	30.08	30.24	26.73
102	26.50	29.73	29.80	26.42
103	26.09	29.38	29.36	26.12
104	25.69	29.02	28.92	25.81
105	25.29	28.67	28.48	25.50
106	24.89	28.31	28.05	25.19
107	24.49	27.96	27.62	24.87
108	24.10	27.59	27.19	24.56
109	23.71	27.23	26.77	24.24
110	23.32	26.87	26.34	23.93
111	22.93	26.51	25.92	23.61
112	22.55	26.15	25.50	23.29
113	22.17	25.78	25.08	22.97
114	21.79	25.42	24.66	22.66
115	21.42	25.05	24.25	22.33
116	21.04	24.68	23.84	22.01
117	20.67	24.31	23.43	21.68
118	20.30	23.94	23.02	21.36
119	19.93	23.57	22.61	21.03
120	19.57	23.20	22.21	20.70
121	19.20	22.83	21.80	20.38
122	18.84	22.46	21.40	20.05
123	18.48	22.09	21.00	19.72

Angle Between Walls	52/38° Crown Molding		45/45° Crown Molding	
	Miter Setting	Bevel Setting	Miter Setting	Bevel Setting
124	18.13	21.71	20.61	19.39
125	17.77	21.34	20.21	19.06
126	17.42	20.96	19.81	18.72
127	17.06	20.59	19.42	18.39
128	16.71	20.21	19.03	18.06
129	16.37	19.83	18.64	17.72
130	16.02	19.45	18.25	17.39
131	15.67	19.07	17.86	17.05
132	15.33	18.69	17.48	16.71
133	14.99	18.31	17.09	16.38
134	14.66	17.93	16.71	16.04
135	14.30	17.55	16.32	15.70
136	13.97	17.17	15.94	15.36
137	13.63	16.79	15.56	15.02
138	13.30	16.40	15.19	14.62
139	12.96	16.02	14.81	14.34
140	12.63	15.64	14.43	14.00
141	12.30	15.25	14.06	13.65
142	11.97	14.87	13.68	13.31
143	11.64	14.48	13.31	12.97
144	11.31	14.09	12.94	12.62
145	10.99	13.71	12.57	12.29
146	10.66	13.32	12.20	11.93
147	10.34	12.93	11.83	11.59
148	10.01	12.54	11.46	11.24
149	9.69	12.16	11.09	10.89
150	9.37	11.77	10.73	10.55
151	9.05	11.38	10.36	10.20
152	8.73	10.99	10.00	9.85
153	8.41	10.60	9.63	9.50
154	8.09	10.21	9.27	9.15
155	7.77	9.82	8.91	8.80
156	7.46	9.43	8.55	8.45
157	7.14	9.04	8.19	8.10
158	6.82	8.65	7.83	7.75
159	6.51	8.26	7.47	7.40
160	6.20	7.86	7.11	7.05
161	5.88	7.47	6.75	6.70
162	5.57	7.08	6.39	6.35
163	5.26	6.69	6.03	6.00
164	4.95	6.30	5.68	5.65
165	4.63	5.90	5.32	5.30
166	4.32	5.51	4.96	4.94
167	4.01	5.12	4.61	4.59
168	3.70	4.72	4.25	4.24
169	3.39	4.33	3.90	3.89
170	3.08	3.94	3.54	3.53
171	2.77	3.54	3.19	3.10
172	2.47	3.15	2.83	2.83
173	2.15	2.75	2.48	2.47
174	1.85	2.36	2.12	2.12
175	1.54	1.97	1.77	1.77
176	1.23	1.58	1.41	1.41
177	0.92	1.18	1.06	1.06
178	0.62	0.79	0.71	0.71
179	0.31	0.39	0.35	0.35

Maintenance

▲WARNING To avoid injury while performing maintenance, always unplug the power cord before working on the saw. Failure to comply may cause serious injury!

▲WARNING Never use gasoline or any highly volatile solvents to clean the miter saw. Failure to comply may cause serious injury!

▲WARNING Use only replacement parts that are identical to the parts list at the end of this manual and reassemble exactly as the original assembly to avoid electrical shock. Failure to comply may cause serious injury!

Replacing Carbon Brushes

Replace both carbon brushes when either has less than 1/4 in. length of carbon remaining, or if the spring or wire is damaged or burned.

To inspect or replace brushes:

1. Unplug the saw.
2. Remove the black plastic cap on the side of the motor
Remove the cap cautiously, because it is spring-loaded.
3. Pull out the brush and replace.
4. Reverse above steps to reassemble. Tighten the cap snugly, but do not over-tighten.

Replace the brush for the other side in the same manner described above.

Note: To reinstall the same brushes, first make sure the brushes go back in the way they came out. This will avoid a break-in period that reduces motor performance and increases wear.

Lower Blade Guard

Do not use the saw without the lower blade guard. The lower blade guard is attached to the saw for your protection. Should the lower guard become damaged, do not use the saw until the damaged guard has been replaced. Develop a regular check to make sure the lower guard is working properly. Clean the lower guard of any dust or buildup with a damp cloth.

▲WARNING When cleaning the lower guard, unplug the saw from the power source receptacle to avoid unexpected startup.

▲WARNING Do not use solvents on the guard. They could make the plastic “cloudy” and brittle.

Saw Dust

Periodically, saw dust will accumulate under the work table and base. This could cause difficulty in the movement of the worktable when setting up a miter cut. Frequently blow out or vacuum up the saw dust.

▲WARNING If blowing saw dust, wear proper eye protection to keep debris from entering eyes.

Lubrication

All the motor bearings in this tool are lubricated with a sufficient amount of high grade lubricant for the life of the unit under normal operating conditions; therefore, no further lubrication is required.

Lubricate the following as necessary:

Chop pivot: Apply light machine oil.

Central pivot of plastic guard: Use light household oil (sewing machine oil) on metal-to-metal or metal-to-plastic guard contact areas as required for smooth, quiet operation. Avoid excessive oil, to which saw dust will cling.

Troubleshooting – Motor

Trouble	Probable Cause	Remedy
Brake does not stop blade within 10 seconds.	<p>Motor brushes not sealed or lightly sticking.</p> <p>Motor brake overheated from use of defective or wrong size blade or rapid ON/OFF cycling.</p> <p>Arbor bolt loose.</p> <p>Brushes cracked, damaged, etc.</p> <p>Other.</p>	<p>Inspect/clean/replace brushes.</p> <p>See MAINTENANCE section.</p> <p>Use a recommended blade. Let cool down. See <i>Removing or Installing the Blade</i> section.</p> <p>Retighten. See <i>Removing or Installing the Blade</i> section.</p> <p>Replace brushes.</p> <p>Contact your Service Center.</p>
Motor does not start	<p>Limit switch failure</p> <p>Brush worn.</p> <p>Fuse blown or circuit breaker tripped on home panel.</p>	<p>Replace limit switch.</p> <p>Replace brushes. See <i>Maintenance</i> section.</p> <p>Verify there is electrical power at the outlet.</p>
Brush spark when switch released.	<p>Worn brush.</p> <p>Other.</p>	<p>Replace brushes. See Maintenance section.</p> <p>Contact your Service Center.</p>

Troubleshooting – Operation

Trouble	Probable Cause	Remedy
Blade hits table.	Misalignment.	See the Setting Cutting Depth section in Adjustments
Angle of cut not accurate. Can not adjust miter.	<p>Miter table unlocked.</p> <p>Saw dust under table.</p>	<p>See the Miter Angle Adjustment section in Operations</p> <p>Vacuum or blow out dust.</p> <p>Important: Wear eye protection.</p>
Cutting arm wobbles.	Loose pivot points.	Contact Service Center.
Cutting arm will not fully raise, or blade guard won't fully close.	<p>Pivot spring not replaced properly after service.</p> <p>Saw dust build-up.</p>	<p>Contact Service Center.</p> <p>Clean and lubricate moving parts.</p>
Blade binds, jams, burns wood.	<p>Improper operation.</p> <p>Dull or warped blade.</p> <p>Improper blade size.</p> <p>Wood is moving during cut.</p>	<p>See Operations section.</p> <p>Replace or sharpen blade.</p> <p>Replace with 12 in. diameter blade.</p> <p>Use hold down clamp to secure workpiece to table.</p>
Saw vibrates or shakes.	<p>Saw blade not round / damaged / loose.</p> <p>Arbor bolt loose.</p>	<p>Replace blade.</p> <p>Tighten arbor bolt.</p>
Laser not aligned	--	Contact Service Center.
Laser turns off	Laser turns off after 20 minutes to prevent heat buildup.	Reset laser switch on trigger handle (turn off, after 2 seconds turn on again).

Parts

Ordering Replacement Parts

To order parts or reach our service department, call 1-800-274-6848 between 7:30am and 5:30pm (CST), Monday through Friday. Having the Model Number and Serial Number of your machine available when you call will allow us to serve you quickly and accurately.

Parts List

Note: Parts without part numbers are for reference only and cannot be purchased individually.

Index No.	Part No.	Description	Size	Qty
1	JMS10SCMS-1	Shaft Sleeve		1
2	JMS12SCMS-2	Pan Head Tapping Screw	M6-14x16	2
3	JMS12SCMS-3	Special Screw		1
4	JMS10SCMS-3	Locator Pin		1
5		Helix Gear		1
6	JMS10SCMS-4	Label: Miter Quick Lock		1
7	JMS12SCMS-7	Warning Label		1
8		Compression Spring		1
9	JMS12SCMS-9	Center Shaft		2
10		Cushion		2
11		Lock Screw		2
12		Nut		1
13		Link		1
14	JMS10SCMS-10	Cord Clamp		1
15	JMS12SCMS-15	Foot		4
16		Release Lever		1
17	JMS12SCMS-17	Slide Plate		3
18	JMS12SCMS-18	Pivot Shaft		1
19	JMS12SCMS-19	Sleeve		1
20	JMS12SCMS-20	Guard Spring		1
21	JMS10SCMS-14	Knob		1
22		Roller		2
23		Bearing		2
24	JMS10SCMS-17	Center Bolt		1
25	JMS10SCMS-18	Arbor Collar		2
26	JMS10SCMS-19	Blade Wrench		1
27	JMS12SCMS-27	Power Cord Clamp		1
28		Compression Spring		1
29	JMS12SCMS-29	Collar		1
30	JMS12SCMS-30	Base Rear Extension		1
31	JMS10SCMS-21	Pin		1
32	JMS12SCMS-32	Dust Shield		2
33	JMS12SCMS-33	Cover		2
34	JMS10SCMS-22	Slide Bar Guide Clamp		2
35		Ball Bearing	608ZZ	4
36		Ball Bearing	6001ZZ	1
37		Ball Bearing	6003ZZ	1
38	JMS12SCMS-38	Linear Motion Bearing	LM30LLU	1
39	TS-1550031	Flat Washer	M5	2
40	TS-1550041	Flat Washer	M6	1
41	TS-1550061	Flat Washer	M8	1
42	TS-155010	Flat Washer	M16	2
43		Flat Washer	M6	5
44	TS-1550061	Flat Washer	M8	1
45	TS-0680021	Flat Washer	1/4	4
46	JMS10SCMS-33	Flat Washer	1/4x1/2x3/32	1
47	TS-0680031	Flat Washer	5/16	2

Parts List

Index No.	Part No.	Description	Size	Qty
48	TS-0680041	Flat Washer	3/8	2
49		Flat Washer	5/16	1
50	TS-0680041	Flat Washer	3/8	1
51	JMS10SCMS-36	External Tooth Lock Washer	M5	2
52	JMS10SCMS-37	Wave Washer	WW-8	2
53	JMS12SCMS-53	Wave Washer	WW-14	2
54		Spring Pin	Ø5x16	4
55		C-Ring	A-17	1
56		E-Clip	E-6	1
57		E-Clip	E-7	1
58		Push Nut	SPN-5	2
59	JMS10SCMS-42	O-Ring	P10	1
60	JMS10SCMS-43	O-Ring	P7	1
61		O-Ring	P30	2
62	TS-1490051	Hex Cap Screw	M8x30	2
63	TS-1490081	Hex Cap Screw	M8x45	1
64	TS-1502011	Socket Head Cap Screw	M5x8	2
65	TS-1503051	Socket Head Cap Screw	M6x20	2
66	TS-1503061	Socket Head Cap Screw	M6x25	1
67	TS-1504051	Socket Head Cap Screw	M8x25	2
68	TS-1504061	Socket Head Cap Screw	M8x30	2
69	TS-1504121	Socket Head Cap Screw	M8x60	1
70	TS-1504101	Socket Head Cap Screw	M8x50	1
71	TS-1522021	Socket Set Screw	M5x8	2
72	TS-1523071	Socket Set Screw	M6x25	2
73	TS-1524041	Socket Set Screw	M8x16	1
74	TS-1523031	Socket Set Screw	M6x10	3
75	JMS12SCMS-75	Socket Head Cap Screw with Lock Washer	M5x16	4
76	JMS10SCMS-55	Socket Head Cap Screw with Lock Washer	M6x16	5
77	JMS12SCMS-77	Socket Head Cap Screw with Washer	M8x40	4
78	JMS12SCMS-78	Pan Head Machine Screw with Washer	M6x12	1
79	JMS10SCMS-59	Truss Head Screw	M5x8	2
80	JMS10SCMS-60	Truss Head Screw	M6x8	4
81	JMS12SCMS-81	Round Washer Head Screw	M5x8	6
82	JMS10SCMS-63	Truss Head Round Neck Screw	M6x10	4
83	JMS10SCMS-65	Pan Head Tapping Screw	M3-24x10	3
84	TS-1533032	Pan Head Screw	M5x10	3
85	TS-2284082	Pan Head Screw	M4x8	6
86	JMS10SCMS-68	Pan Head Tapping Screw	M5-16x25	1
87	JMS10SCMS-69	Pan Head Tapping Screw	M4-18x25	5
88	JMS10SCMS-70	Truss Head Tapping Screw	M4-16x12	1
89	TS-1534032	Pan Head Screw	M6x10	2
90	TS-2284082	Pan Head Screw	M4x8	1
91	TS-1532042	Pan Head Screw	M4x12	2
92	TS-1532052	Pan Head Screw	M4x16	2
93	JMS10SCMS-72	Pan Head Screw	M5x8	3
94	TS-1533062	Pan Head Screw	M5x20	1
95	TS-1533032	Pan Head Screw	M5x10	2
96	TS-1534042	Pan Head Screw	M6x12	3
97	TS-1534052	Pan Head Screw	M6x16	2
98	JMS10SCMS-78	Pan Head Round Neck Screw	M6x12	1
99		Rivet	Ø6x10	4
100	TS-1540041	Hex Nut	M6	2
101	TS-1540061	Hex Nut	M8	2
102	TS-1541031	Nylon Insert Lock Nut	M8	3
103	TS-1541041	Nylon Insert Lock Nut	M10	1
104	TS-2342161	Nylon Insert Lock Nut	M16	1

Parts List

Index No.	Part No.	Description	Size	Qty
105		Nylon Insert Lock Nut	M6	2
106	TS-1541031	Nylon Insert Lock Nut	M8	1
107	JMS10SCMS-85	Strain Relief		1
108	JMS10SCMS-210	Cable Clamp	1/8"	1
109	JMS10SCMS-87	Cable Clamp	3/8"	1
110	JMS10SCMS-88	Terminal		2
111	JMS12SCMS-111	Locking Cable Tie		1
112	JMS10SCMS-208	Trigger Switch		1
113	JMS12SCMS-113	Steel Ball	Ø6.3	2
114	JMS12SCMS-114	Arbor Bolt		1
115	JMS10SCMS-92	Washer	M8x23x1.5	2
116		Pin	Ø5x16	2
117	JMS12SCMS-117	Compression Spring		2
118	JMS12SCMS-118	Knob		2
119		Stop Screw		1
120	JMS12SCMS-120	Base		1
121	JMS12SCMS-121	Fence Extension, Left		1
122	JMS12SCMS-122	Saw Arm		1
123	JMS12SCMS-123	Fence Extension, Right		1
124		Blade Guard		1
125	JMS12SCMS-125	Fence		1
126		Pivot Support		1
127		Rear Slide Bar Seat		1
128	JMS10SCMS-98	Pointer		1
129	JMS12SCMS-129	Upper Handle Segment		1
130		Arbor		1
131	JMS12SCMS-131	Bracket		1
132	JMS12SCMS-132	Handle		1
133	JMS12SCMS-133	Pointer, Left		1
134	JMS12SCMS-134	Pointer, Right		1
135	JMS12SCMS-135	Cord Wrap Bracket		2
136	JMS12SCMS-136	Gear Box Cover		1
137	JMS10SCMS-100	Anchor Plate		1
138		Guard Plate		1
139	JMS10SCMS-101	Pulley		1
140		Gear Shaft		1
141	JMS12SCMS-141	Power Cord		1
142	JMS12SCMS-142	V-Ribbed Belt	200J8	1
143	JMS12SCMS-143	Guide Holder		1
144	JMS10SCMS-103	Warning Label: Avoid Exposure		1
145	JMS10SCMS-104	Bushing		1
146		Locating Bar		1
147	JMS12SCMS-147	Special Bolt		1
148	JMS12SCMS-148	Bevel Locating Bar		1
149	JMS12SCMS-149	Pivot Shaft		1
150	JMS10SCMS-105	Locking Rod		1
151		Slide Bar, Right		1
152		Slide Bar, Left		1
153	JMS10SCMS-108	Pivot Shaft		1
154	JMS12SCMS-154	Socket Set Screw	M8x6	2
155		Plate		2
156	JMS12SCMS-156	Bar		1
157	JMS12SCMS-157	Locking Handle Assembly		1
158	JMS12SCMS-158	Blade Guard Assembly		1
159	JMS12SCMS-159	Gear Shaft Assembly		1
160	JMS12SCMS-160	Arbor Assembly		1
161		Key	6x6x8	1

Parts List

Index No.	Part No.	Description	Size	Qty
162	JMS12SCMS-162	Pan Head Tapping Screw	M6-14x25	2
163	JMS10SCMS-110	Table Insert, Right		1
164	JMS10SCMS-111	Table Insert, Left		1
165		Collar		1
166	JMS12SCMS-166	Bearing Protector		1
167	JMS10SCMS-113	Shaft		1
168	JMS12SCMS-168	Cord Clamp		1
169	JMS12SCMS-169	Torsion Spring		1
170		Pin	Ø4x30	1
171		Pin	Ø4x35	1
172	JMS10SCMS-114	Set Nut		1
173	JMS10SCMS-115	Screw Stop		1
174	JMS12SCMS-174	Blade Wrench Holder		1
175	JMS12SCMS-175	Lever		1
176		Lock Handle		1
177	JMS12SCMS-177	Slide Bar Guard		1
178	JMS10SCMS-116	Lock Knob		1
179	JMS10SCMS-117	Lock Knob		1
180	JMS10SCMS-118	Anchor Plate		1
181	JMS10SCMS-119	Compression Spring		1
182		Pin	Ø4x22	1
183		Spring Pin	Ø2.5x9	2
184	JMS10SCMS-121	Compression Spring		1
185	TS-1523051	Socket Set Screw	M6x16	2
186	JMS10SCMS-123	SHCS with Lock Washer & Flat Washer	M5x20	4
187	JMS10SCMS-124	SHCS with Lock Washer & Flat Washer	M5x12	4
188	JMS12SCMS-188	Handle		1
189	TS-1482031	Hex Cap Screw	M6x16	1
190	JMS10SCMS-162	Slotted Set Screw	M6x8	4
191	JMS12SCMS-191	Truss Head Screw	M5x8	1
192	JMS10SCMS-170	Rocker Switch		1
193	JMS12SCMS-193	Label: Bevel Lock		1
194	JMS12SCMS-194	Pan Head Tapping Screw	M5-12x30	1
195	JMS12SCMS-195	Lower Handle Segment		1
196	SB-6MM	Steel Ball	Ø6	2
197		Release Lever Housing		1
198	JMS10SCMS-171	Warning Label		1
199	JMS12SCMS-199	Dust Bag		1
200	JMS10SCMS-172	Label: Do Not Remove		2
201	JMS12SCMS-201	Support, Left		1
202	JMS12SCMS-202	Support, Right		1
203	JMS12SCMS-203	Release Lever & Housing Assembly		1
204	JMS12SCMS-204	Support Bolt		2
205	JMS12SCMS-205	Spring		2
206	JMS12SCMS-206	Table		1
207	JMS10SCMS-174	Rivet		2
208	TS-1550041	Flat Washer	M6	4
209	JMS12SCMS-209	Locking Knob		1
210	JMS12SCMS-210	Plate		1
211	JMS10SCMS-176	Upper Handle		1
212	JMS10SCMS-177	Lower Handle		1
213	JMS10SCMS-178	Laser Housing		1
214	JMS10SCMS-181	Locking Handle Assembly		1
215	JMS12SCMS-215	Slide/Bevel Arm		1
216	JMS10SCMS-183	Clear Panel		1
217		Lock Handle		2
218	JMS10SCMS-186	Guard Plate		2

Parts List

Index No.	Part No.	Description	Size	Qty
219	JMS10SCMS-187	Green Laser Controller Assembly		1
220	JMS10SCMS-188	Green Laser		1
221	JMS12SCMS-221	Locking Handle Assembly, Right		1
222	JMS12SCMS-222	Locking Handle Assembly, Left		1
223	JMS12SCMS-223	Swivel Support Assembly		1
224	JMS12SCMS-224	Guard Plate		1
225	JMS12SCMS-225	Saw Blade	12"x60Tx1" Arbor	1
226	JMS10SCMS-194	Clamp Hold Down Assembly		1
227	JMS10SCMS-195	Lead Wire		1
228	JMS12SCMS-228	Laser Housing Bracket		1
229	JMS12SCMS-229	ID Label		1
230	JMS12SCMS-230	JET Label		1
231	JMS10SCMS-198	Label: Laser Caution		1
232	JMS12SCMS-232	Bevel Angle Scale		1
233	JMS12SCMS-233	Miter Angle Scale		1
234	JMS12SCMS-234	JET Label for Slide Bar Guard		1
235	JMS10SCMS-199	JET Label for Pulley Cover		1
236	JMS10SCMS-200	Label: Laser On/Off		1
237	JMS10SCMS-204	JET Label for Handle		1
238	JMS12SCMS-238	Compression Spring		1
239	JMS10SCMS-2	Knob		1
240	JMS12SCMS-240	Motor		1
241	JMS12SCMS-241	Pulley Cover		1
242	JMS10SCMS-99	Disc		1
243	JMS12SCMS-243	Motor Brush		2
244	JMS12SCMS-244	Motor Brush Cover		2
245	JMS10SCMS-155	Washer		1

Assembly Drawing

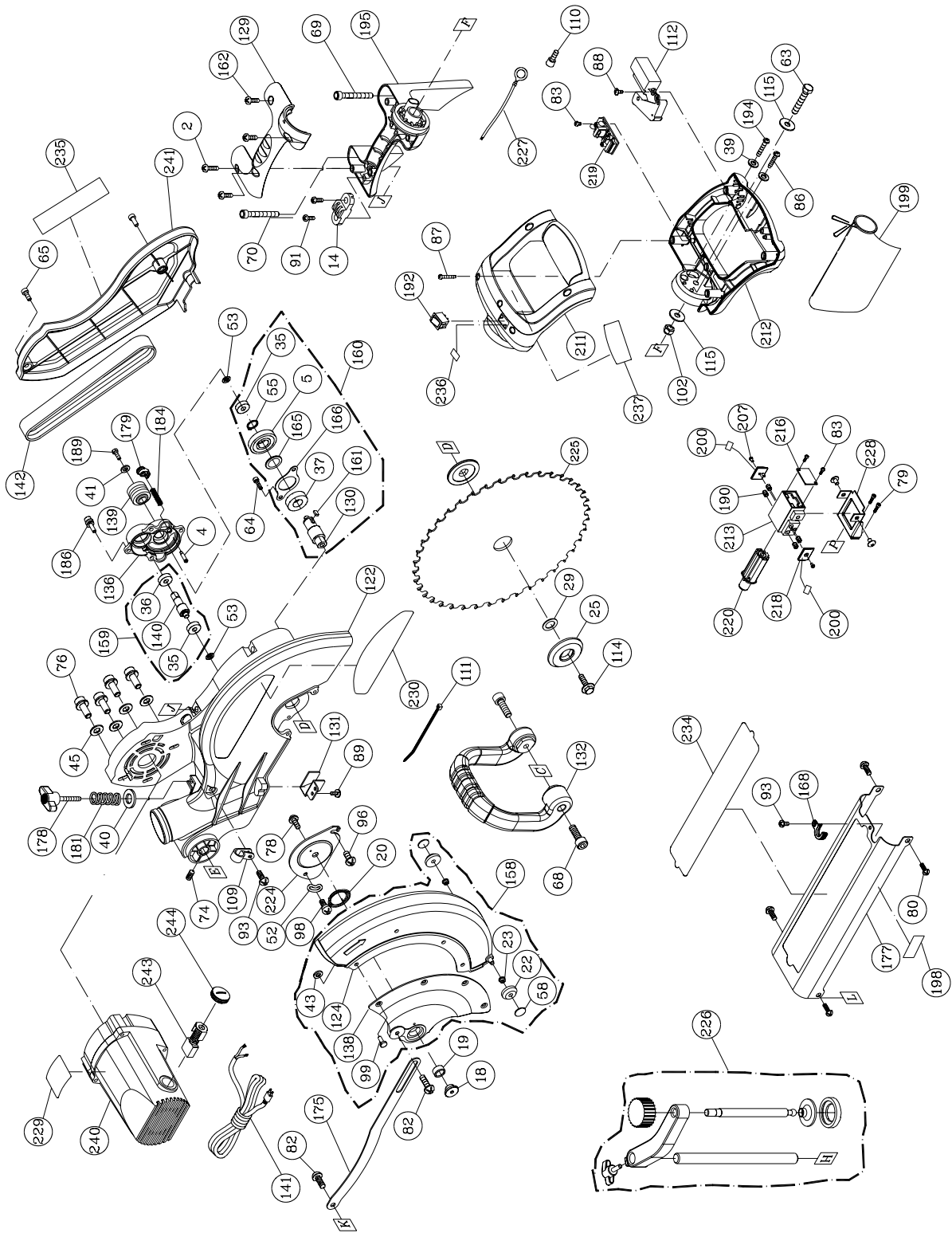

Assembly Drawing

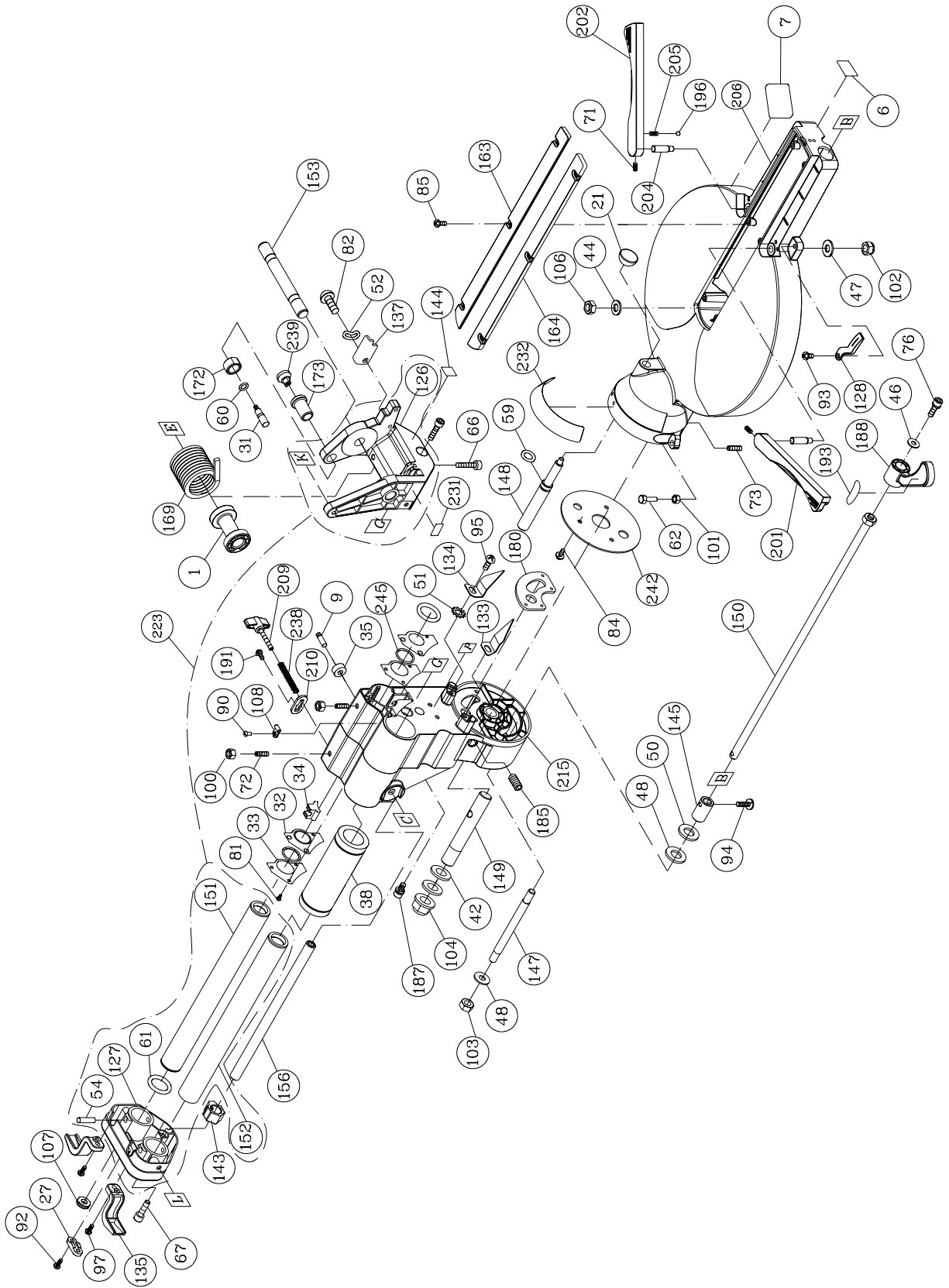

Assembly Drawing

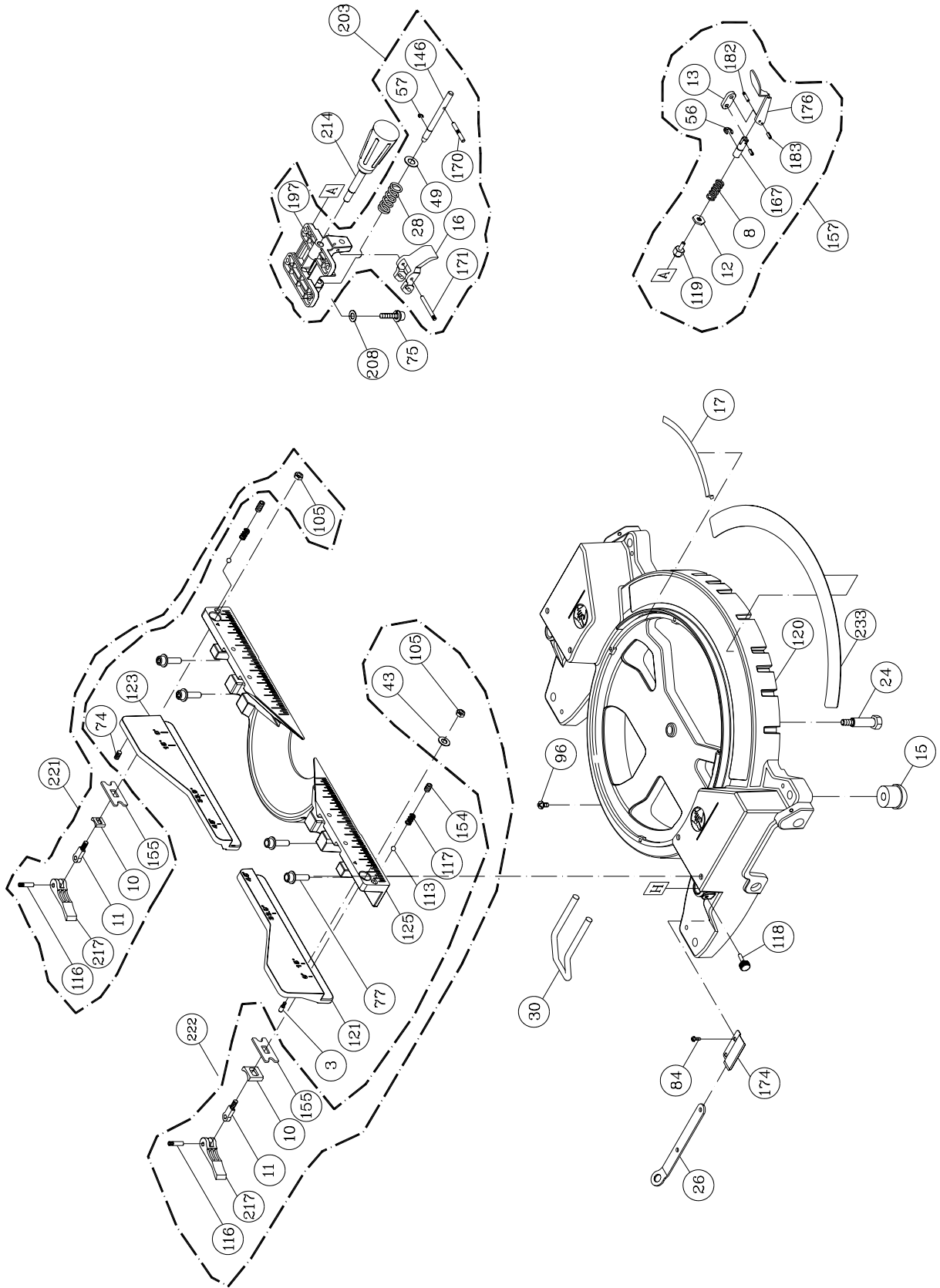

Wiring Diagram

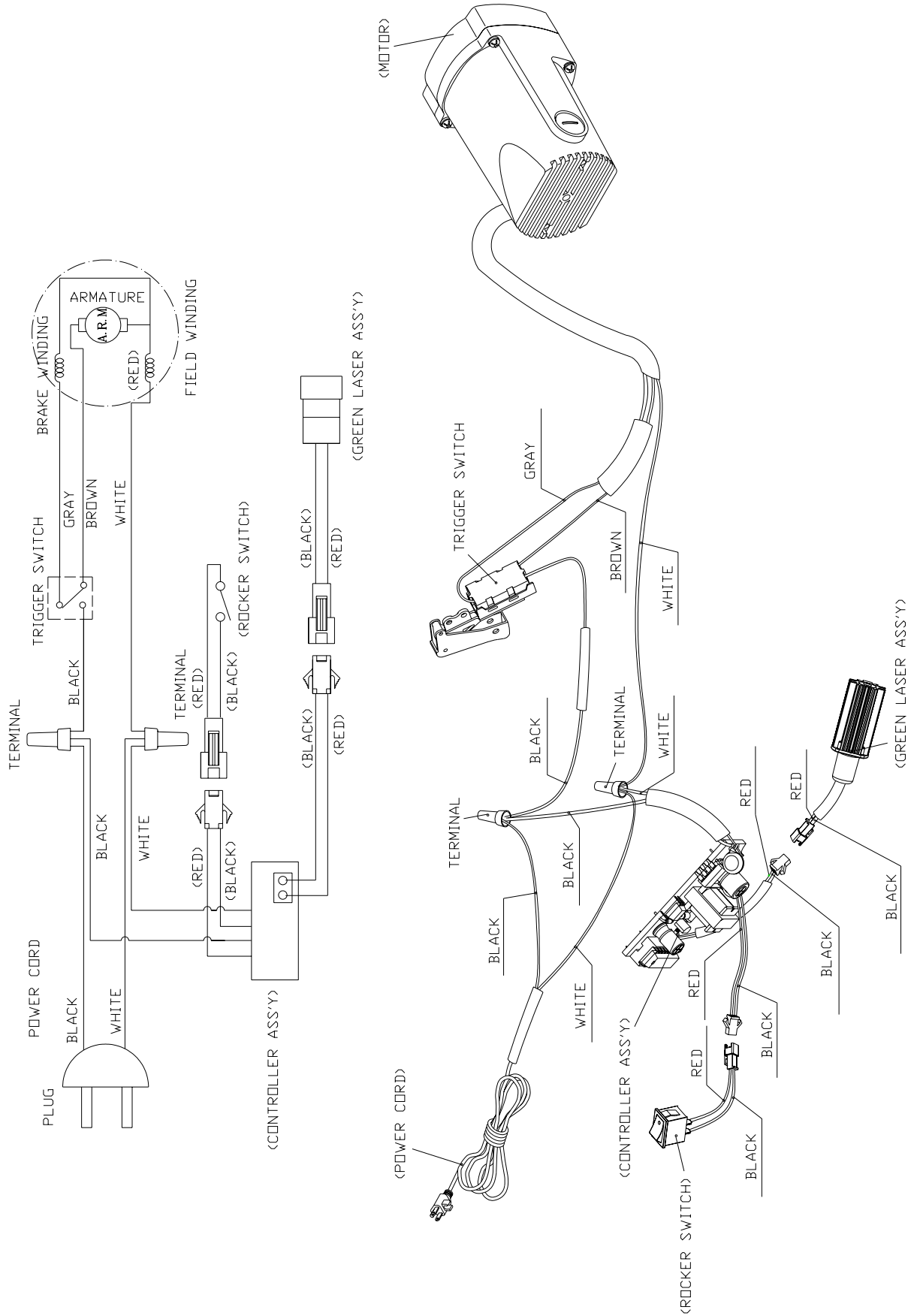



WMH Tool Group, Inc.
2420 Vantage Drive
Elgin, Illinois 60124
Phone: 800-274-6848
www.wmhtoolgroup.com